



Building Science Research Highlights

BCBEC
Annual General Meeting & Conference
2009.09.22

Chris Schumacher
Building Science Corp. | Somerville MA
Building Science Consulting Inc. | Waterloo ON

Presentation Outline

- Coquitlam Test Hut
- 0.5 pound ocSPF Roofs in Vancouver
- The Thermal Metric Project

Coquitlam Test Hut



The Partners

- Gauvin 2000 Construction
 - Location, labour & materials
- Building Science Corp. / U of W
 - Monitoring equipment & expertise

- DuPont, Icynene & James Hardie
 - “Hands Off” Industry Partners
 - Materials & some funding

The Objective (2005)

- Gain a better understanding of the moisture performance of historical low-rise wall assemblies in the Lower Mainland of BC
 - Where have we been?
 - Where are we?
 - Where should we go?

Specific Questions

- How is the moisture performance of wall assemblies influenced by:
 - Amount of insulation
 - Interior vapor control strategy
 - Type of cladding
 - Drained & ventilated gaps behind cladding
 - Exterior insulating sheathing

The Approach

- The Spectrum of Research in Building Science

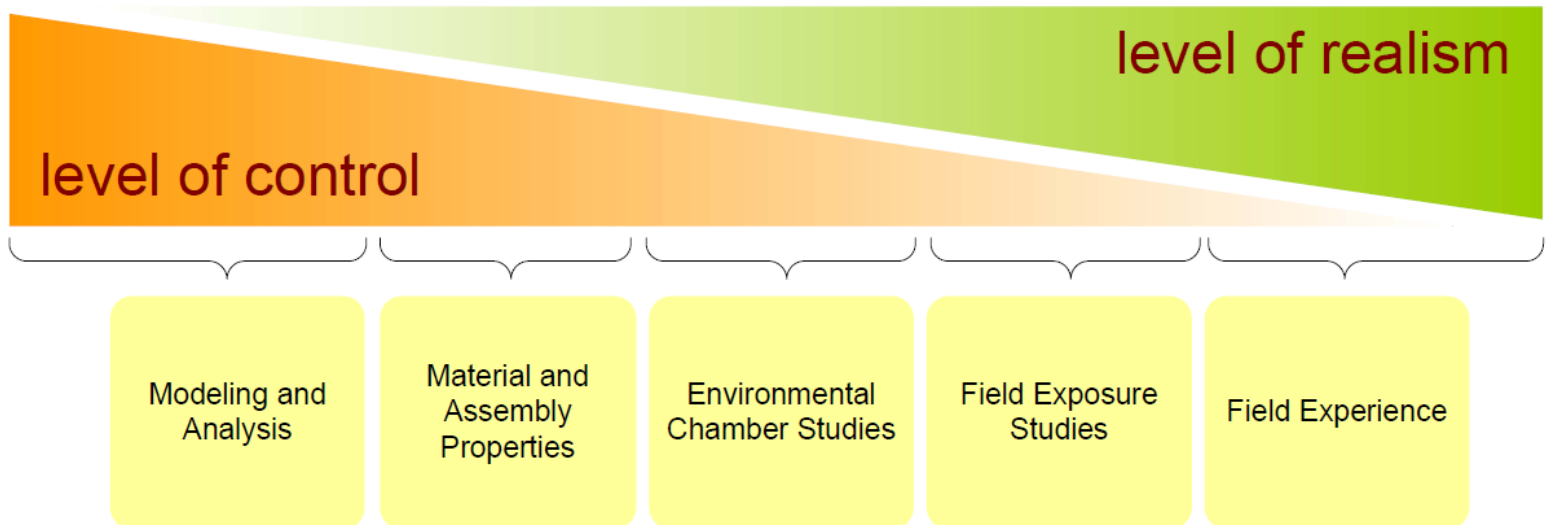

Why a Test Hut?

➤ Control

- construction details, materials, workmanship
- indoor climate
- simulated leaks (“wetting events”)

➤ Realism

- full scale
- real weather

Test Hut Details

- Roof top test hut
- 7 wall panels per orientation
- Full weather station, driving rain, solar

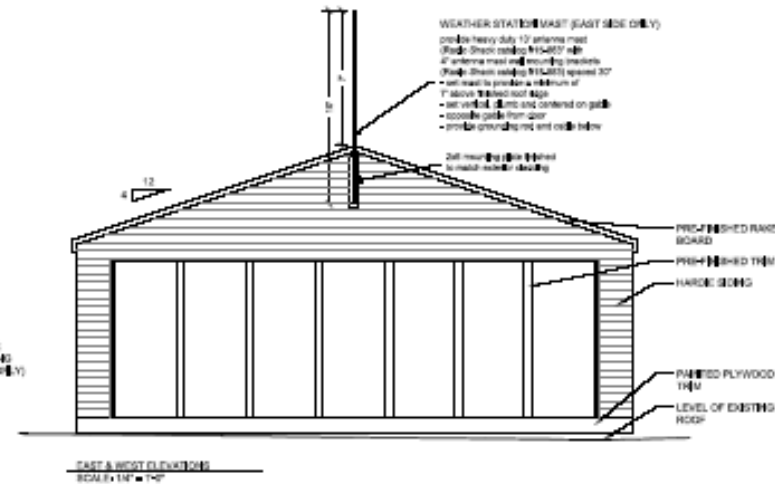
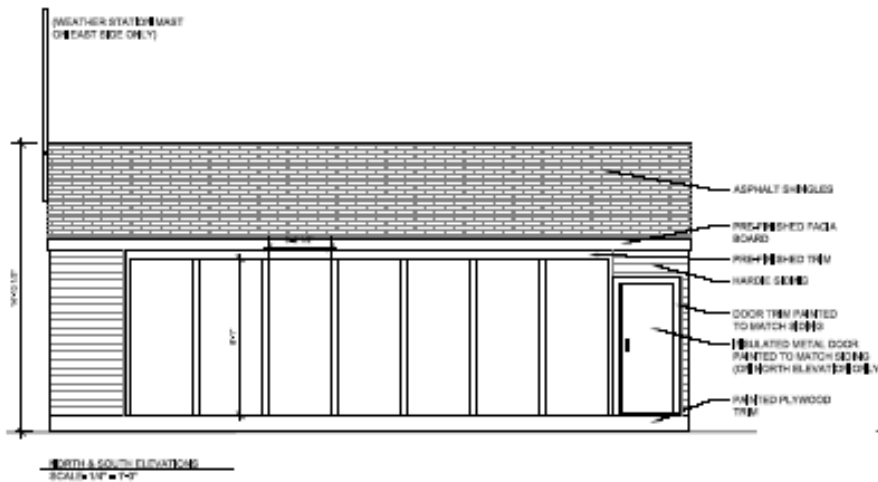

Wall Panel Details

- Walls start with:
 - J-grade Lumber
 - Fiberglass batt
 - Painted GWB

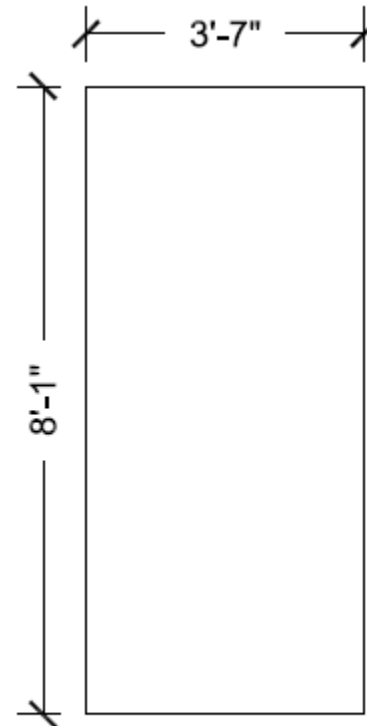

FRAMED ROUGH
OPENING

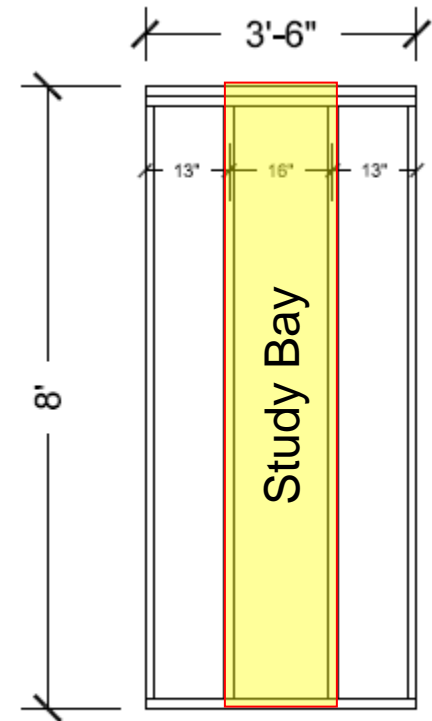

FRAMING OF TYPICAL
TEST PANEL

W1960	Early 2x4 (R-8 kraft paper)	Typical of 1960s (before major problems)	E1 W1 N1 S1	kraft paper, face stapled R-8 fiberglass batt 3/8" plywood single 30 minute paper
W1980	Energy Efficient (air-tight, 6 mil poly)	Typical of 1980s & 90s (beginning of problems)	E2 W2 N2 S2	6 mil poly, sealed R-20 fiberglass batt 1/2" OSB single 30 minute paper
W1980 ADA	Energy Efficient (air-tight drywall, no poly)	Similar to 1980s & 90s but latex paint vapor barrier	E3 W3 N3 S3	R-20 fiberglass batt 1/2" OSB single 30 minute paper
W2000R S	Energy Efficient (6 mil poly, 3/4" cavity)	Modern rainscreen wall incorporating ventilated 3/4" cavity (current solution)	E5 W5	6 mil poly, sealed R-20 fiberglass batt 1/2" OSB double 30 minute paper 3/4" cavity w/ backer board
W2005 D-ADA	Energy Efficient (no poly, Tyvek)	Modern wall incorporating drainage space in lieu of 3/4" cavity (alternate drain systems)	E4 W4 N4 S4	R-20 fiberglass batt 1/2" OSB 30 minute paper Corrugated SBPO
W2000 RS-ADA	Energy Efficient (no poly, 3/4" cavity)	Rainscreen wall with latex paint vapor control (role of poly)	E6 W6	R-20 fiberglass batt 1/2" OSB double 30 minute paper 3/4" cavity w/ backer board
W2005 FC-RS	Hardie Strapped (no poly, 3/4" cavity)	As stucco rainscreen wall but with no poly	N5 S5	R-20 fiberglass batt 1/2" OSB Tyvek Homewrap 3/4" cavity
W2005 FC-D	Hardie Direct (no poly, direct applied)	As stucco drained wall but with no poly	N6 S6	R-20 fiberglass batt 1/2" OSB Tyvek Homewrap
W2005 EIS	(no poly, OSB, XPS insulation)	Drained stucco wall with exterior insulation and wood sheathing.	E7 W7	R-20 fiberglass batt 1/2" OSB Tyvek Drain Wrap 1" Dow Styrofoam SM
W2005 EI	Exterior Insulated (no poly, no OSB, XPS insulation)	Drained stucco wall on exterior insulation, no wood sheathing	N7 S7	R-20 fiberglass batt 1" Dow Styrofoam SM Tyvek Drain Wrap

1960s 2x4 R-12 paper-backed batt

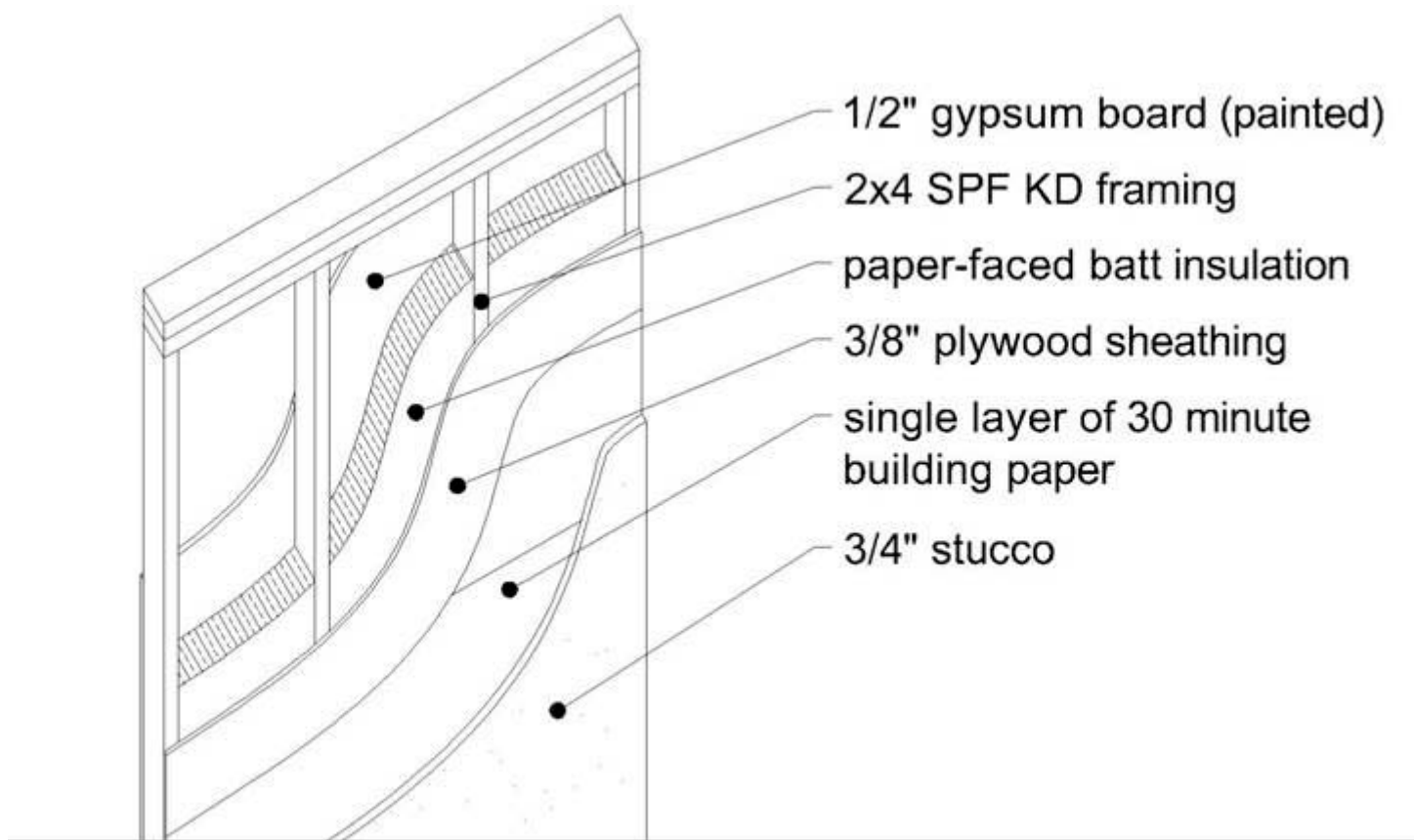

1980s Energy Efficient 2x6 (airtight w/poly)

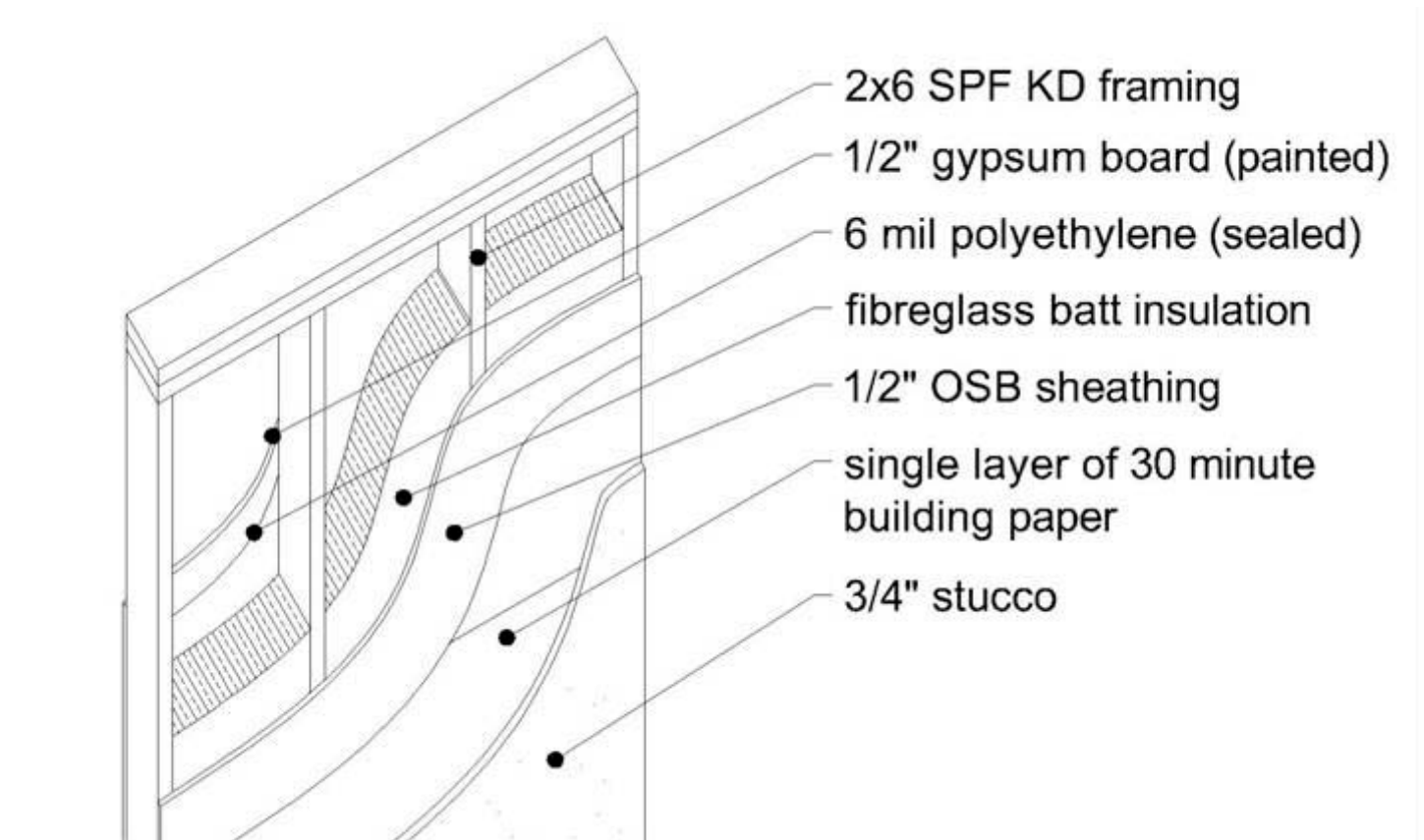

1980s Energy Efficient 2x6 (ADA, no poly)

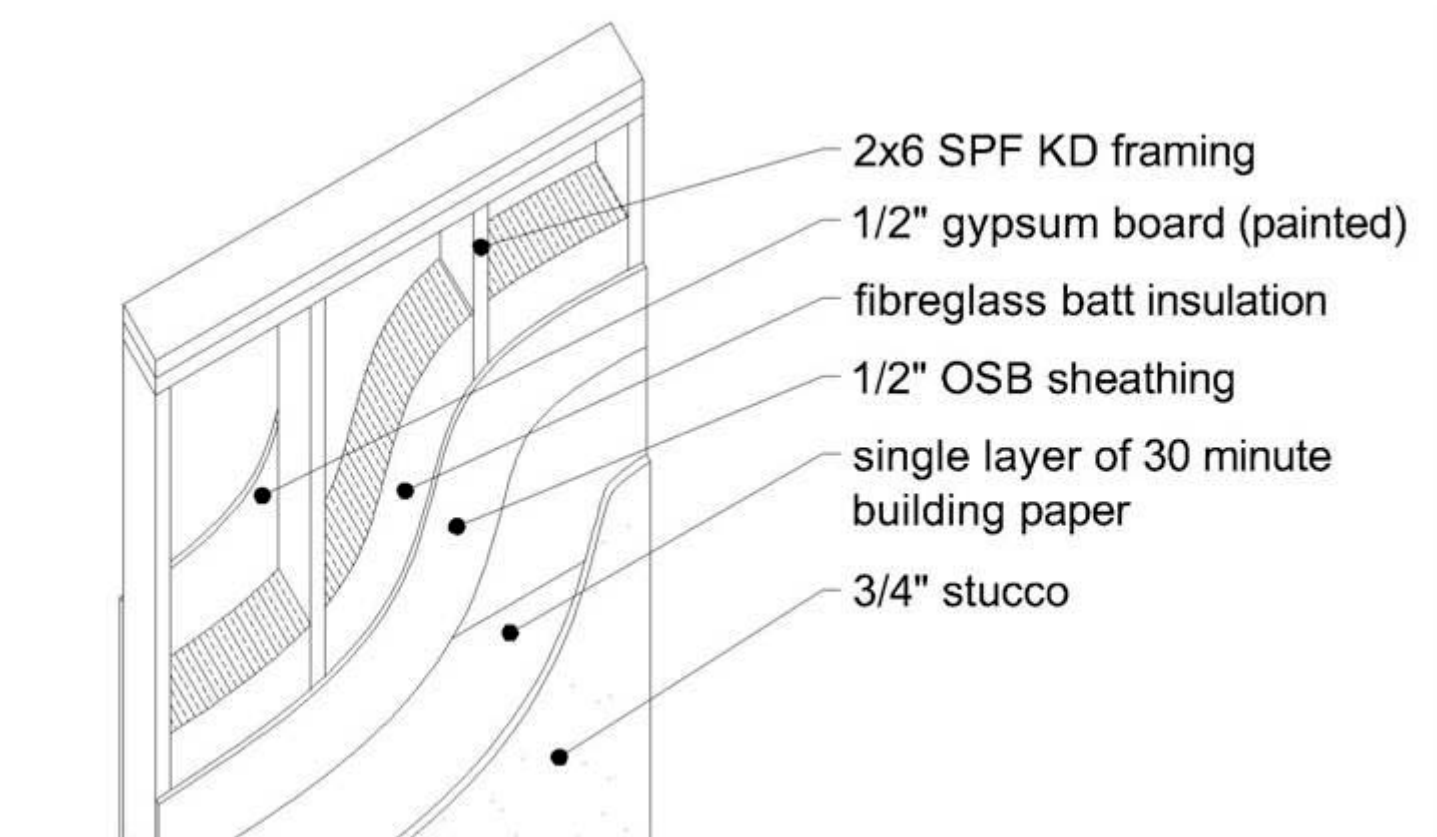

2005 US Energy Efficient, Drained (no poly)

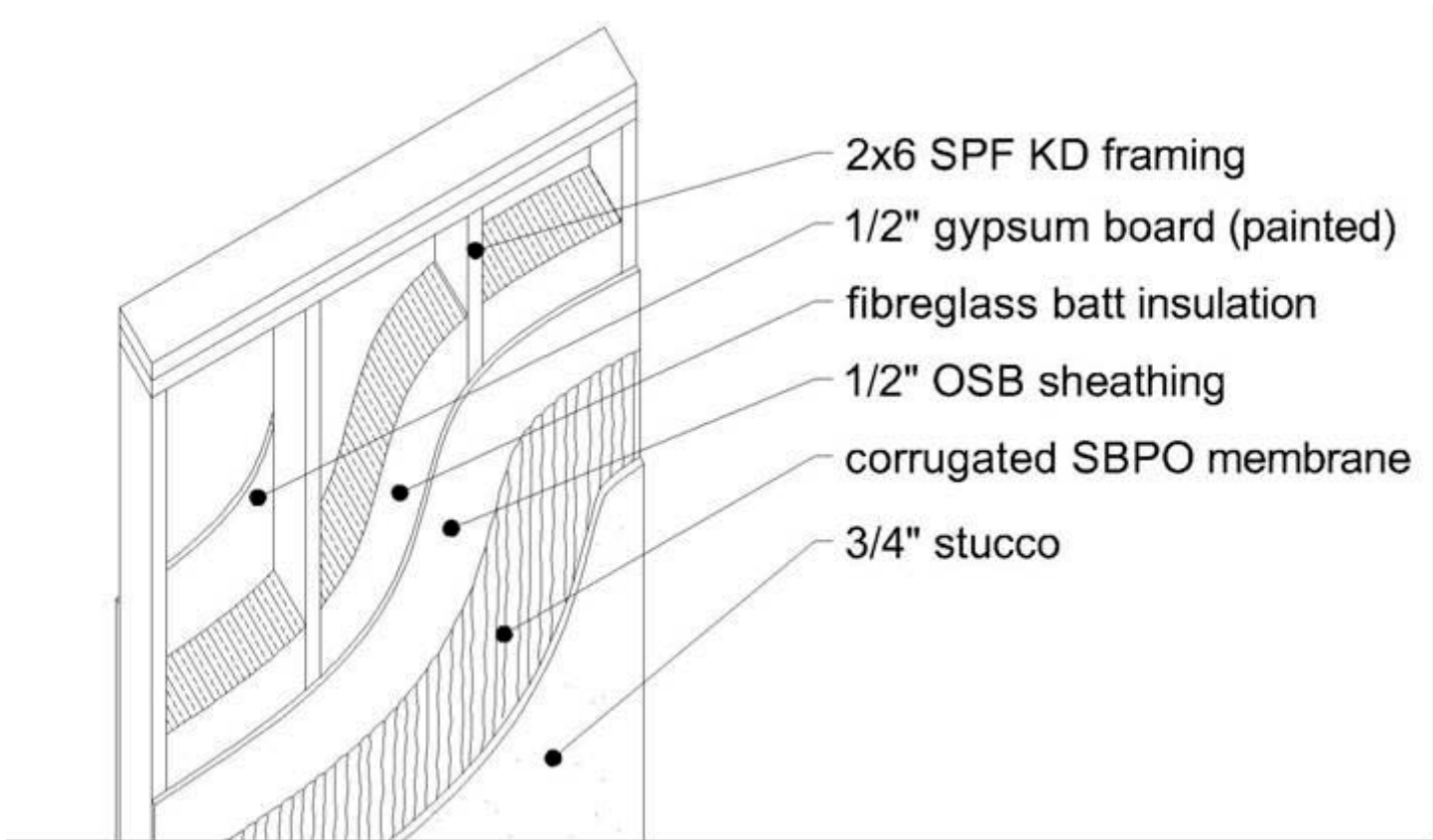

2000s Rainscreen 2x6 (poly, $\frac{3}{4}$ " drained, ventilated gap)

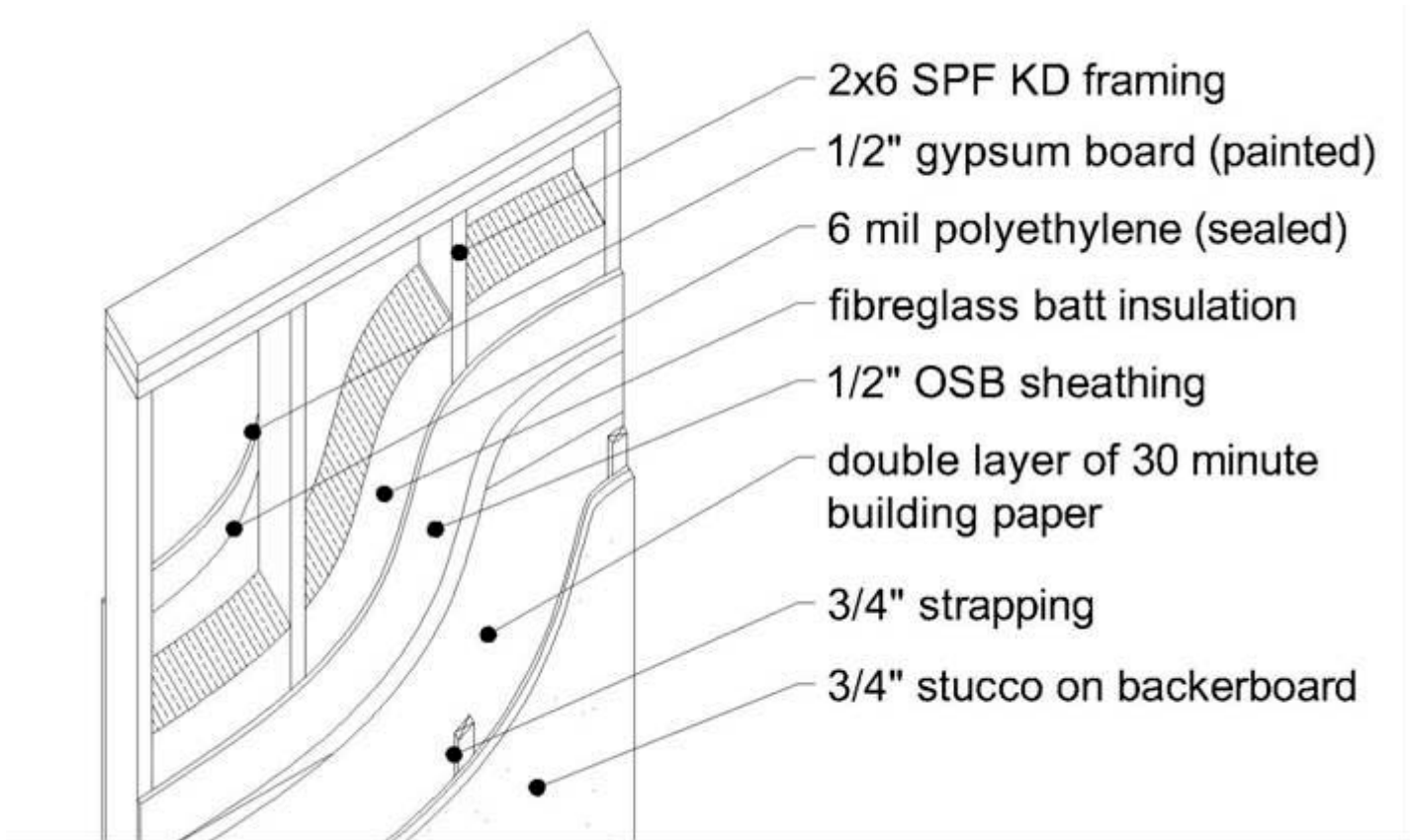

2000s Rainscreen 2x6 (no poly, $\frac{3}{4}$ " drained, ventilated gap)

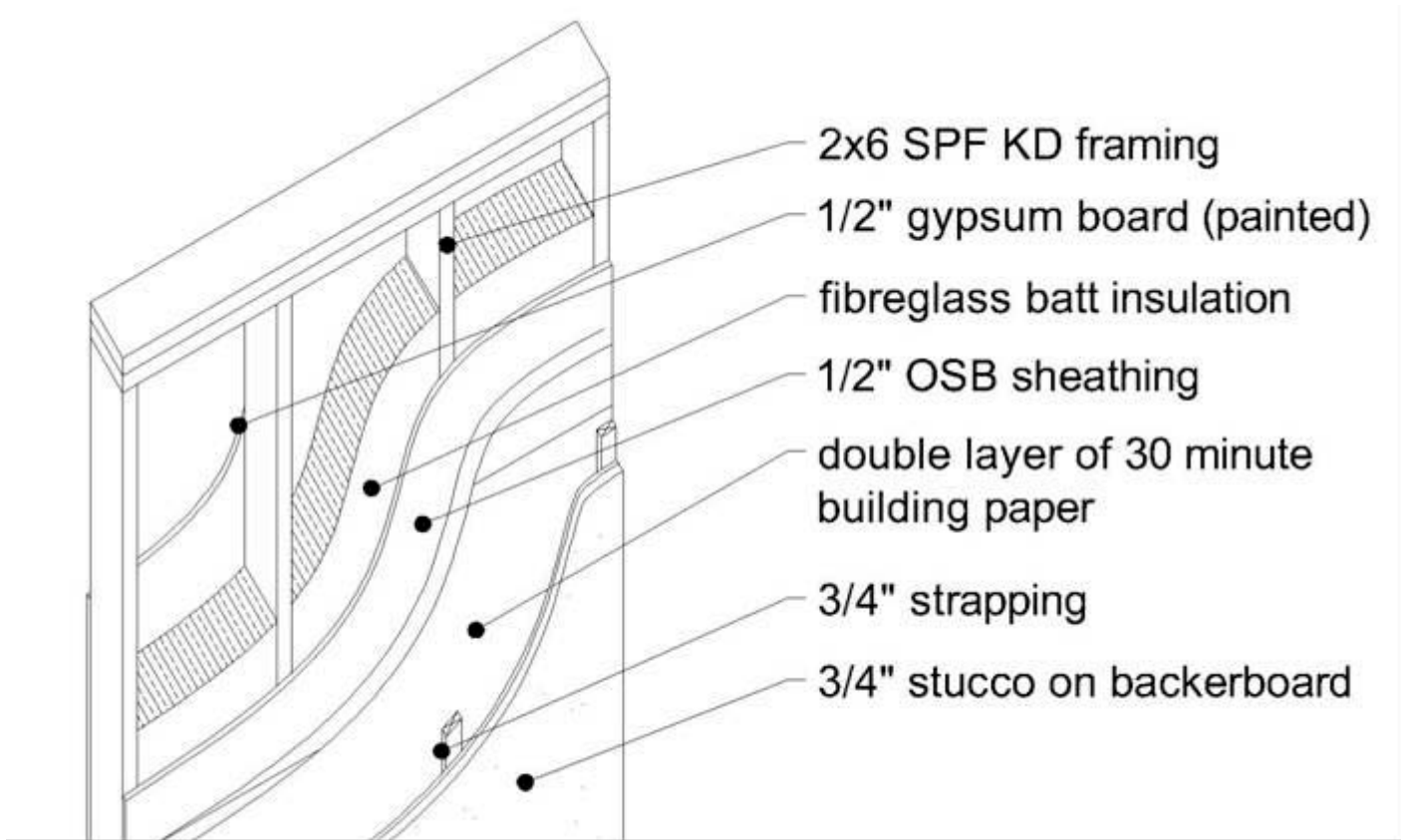

Next Gen (2005+) (no poly, drained, insulation)

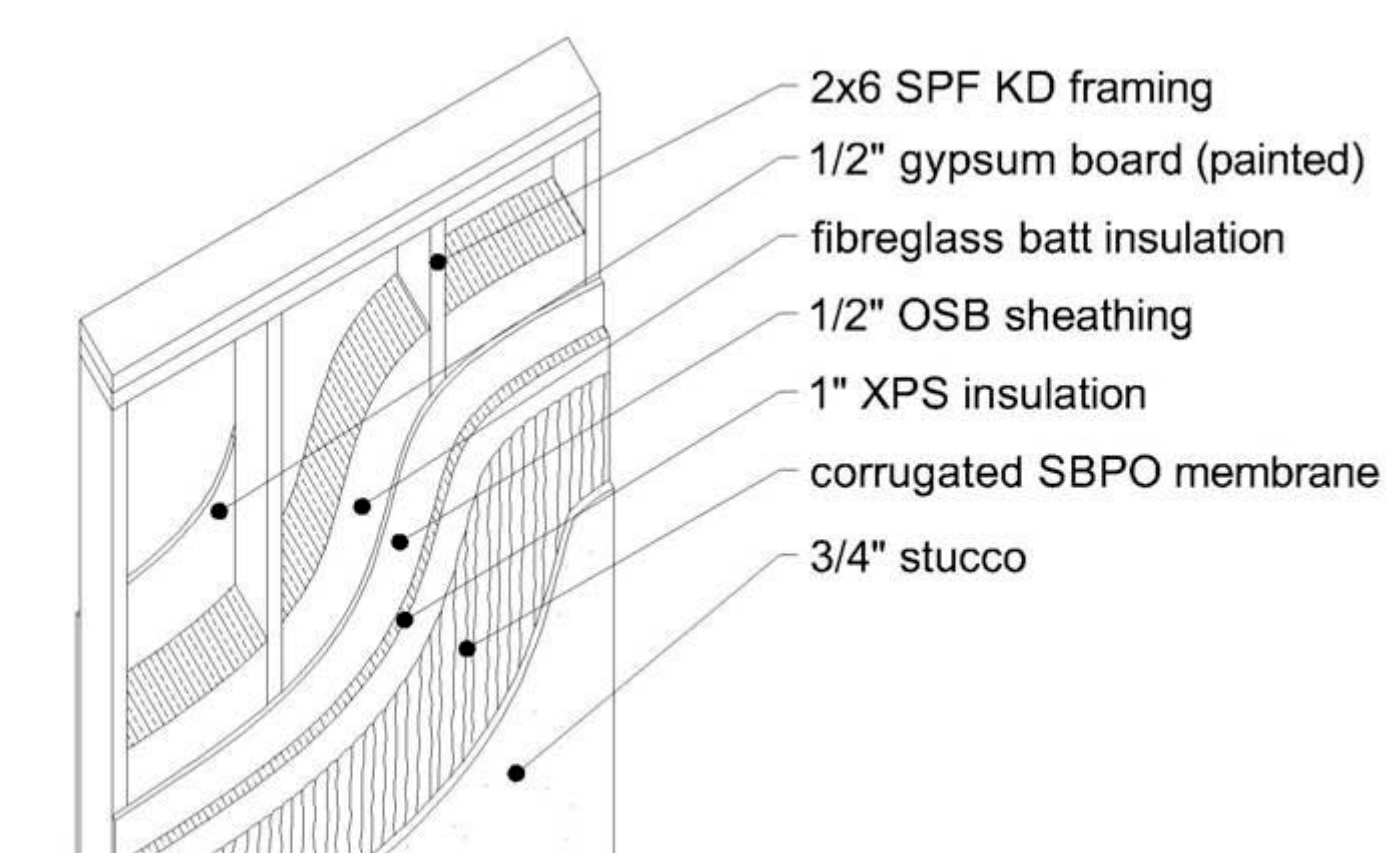

Wall Panel Instrumentation

- Measure moisture storage and temp
 - decay hazards, mold
- Measure critical temperatures
 - Condensation surfaces
 - e.g. sheathing, poly, bottom plate, etc.
- Measure gradients in moisture and temp
 - Infer energy flow
 - Infer moisture flow

Typical Sensor Layout

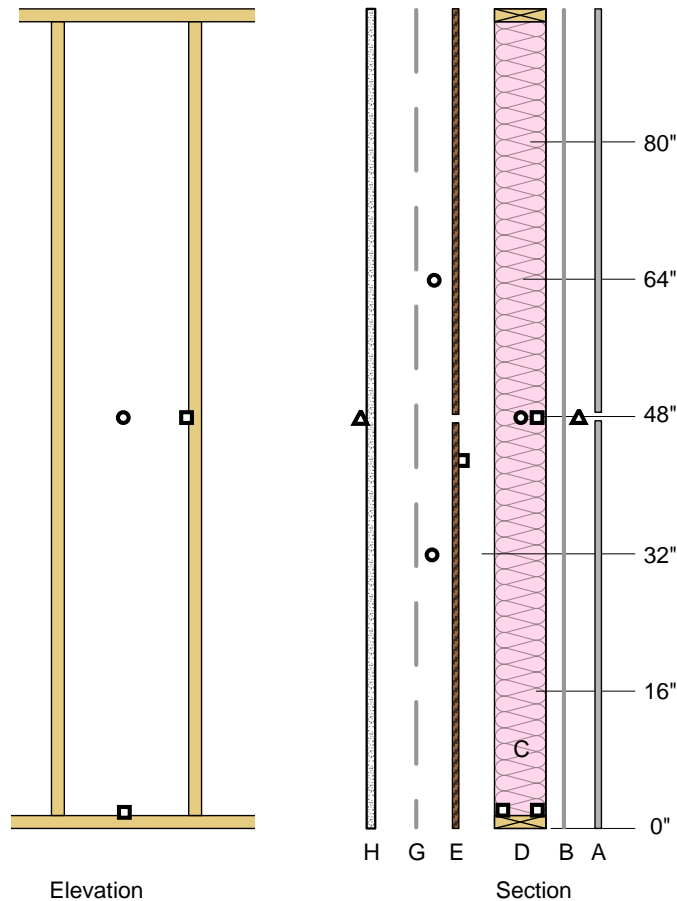

Assembly

Layer	Function	Description
A	Interior Finish	gypsum wall board
B	Vapor Control	poly
C	Studspace	fiberglass batt
D	Framing	2x6
E	Sheathing	½" OSB
F	Sheathing Membrane	#15 felt
G	Drainage Gap	none
H	Cladding	stucco

Sensor Package

Layer	Code	Location
A	taem	Interior finish, exterior face, 48"
C	r/tcnm	Studspace, interstitial, 48"
D	m/tdem	Framing, interior edge, middle
D	m/tdeb	Framing, exterior edge, bottom plate
D	m/tdib	Framing, interior edge, bottom plate
E	m/tenm	Sheathing, interstitial, 48"
G	r/tgnw	Drainage space, interstitial, 32"
G	r/tgne	Drainage space, interstitial, 64"
H	them	Cladding, exterior surface, 48"

- Relative Humidity and Temperature Sensor Package
- Moisture Content Pins and Temperature Sensor Package
- ▲ Temperature Sensor
- ▧ Moisture Content Wafer and Temperature Sensor Package
- Moisture Content Pins

Sensors & Wetting Systems



The Test Sequence

- Phase 1 – Baseline
 - “Typical” indoor RH & temp conditions
 - Real outdoor weather conditions

- Phase 2 – Inside Wetting
 - Inject water into wetting system installed on inside surface of exterior sheathing

- Phase 3 – Outside Wetting

Monitoring Results...

Rainfall

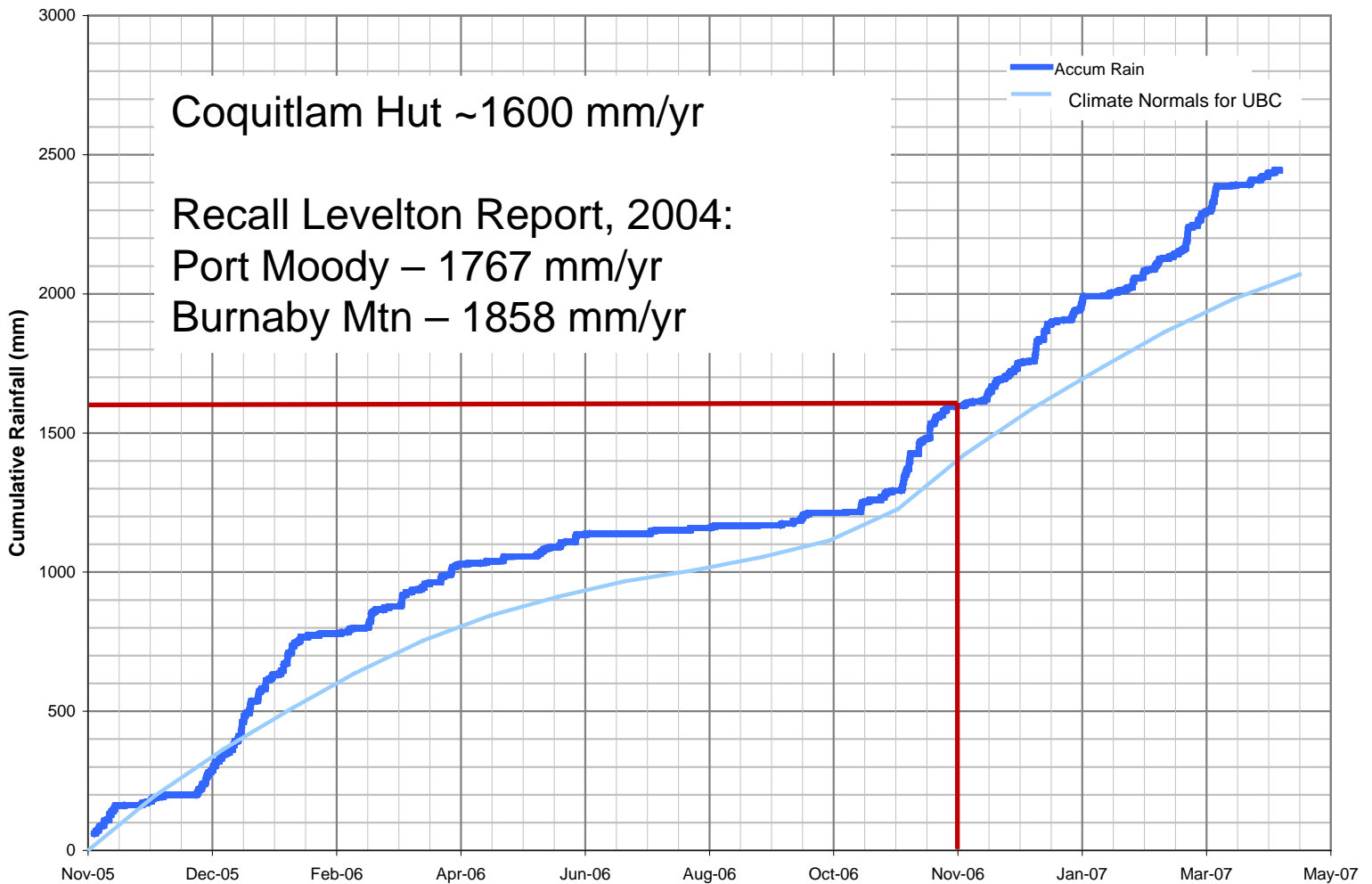



Outdoor T & RH

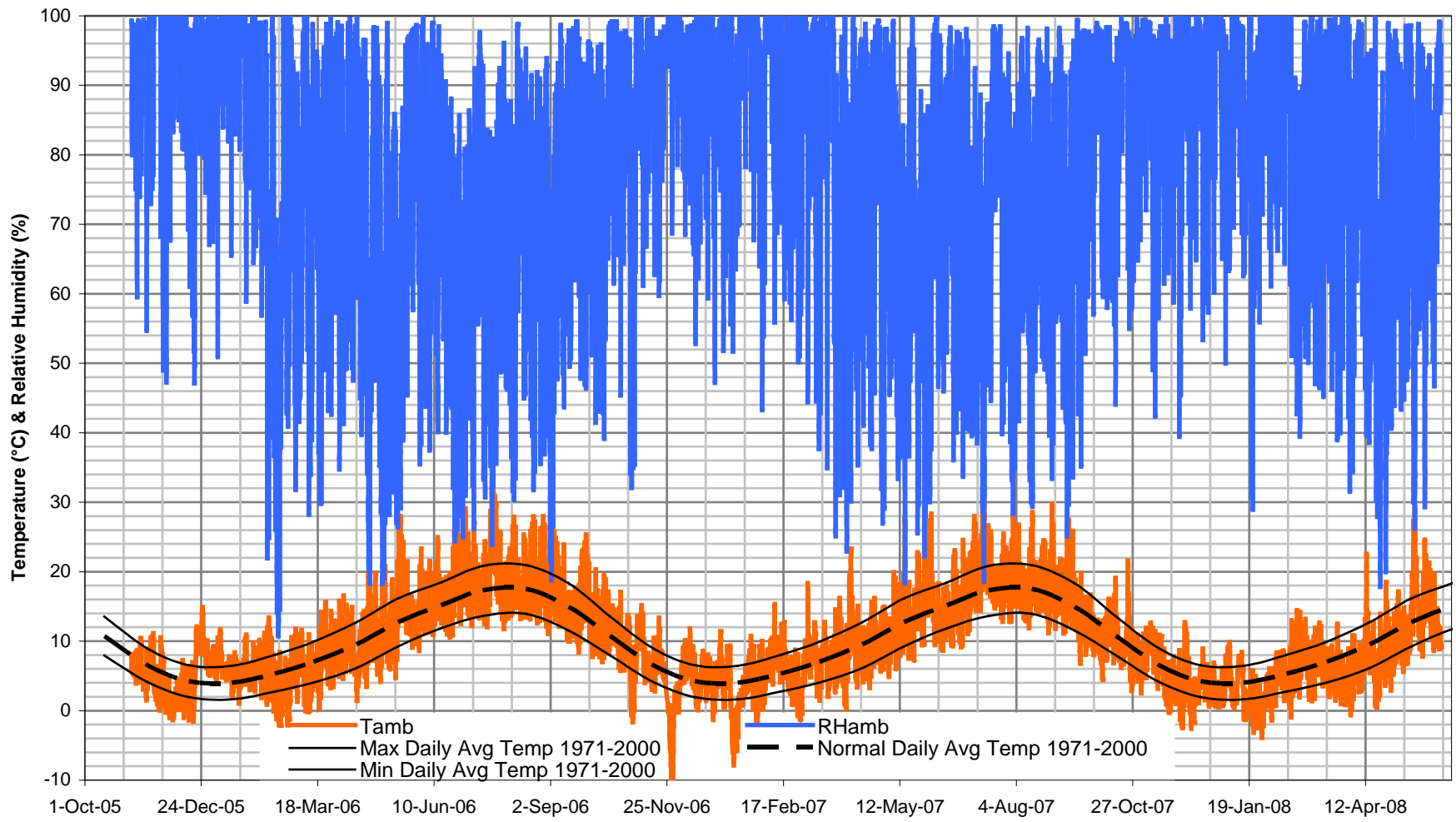



Indoor T & RH

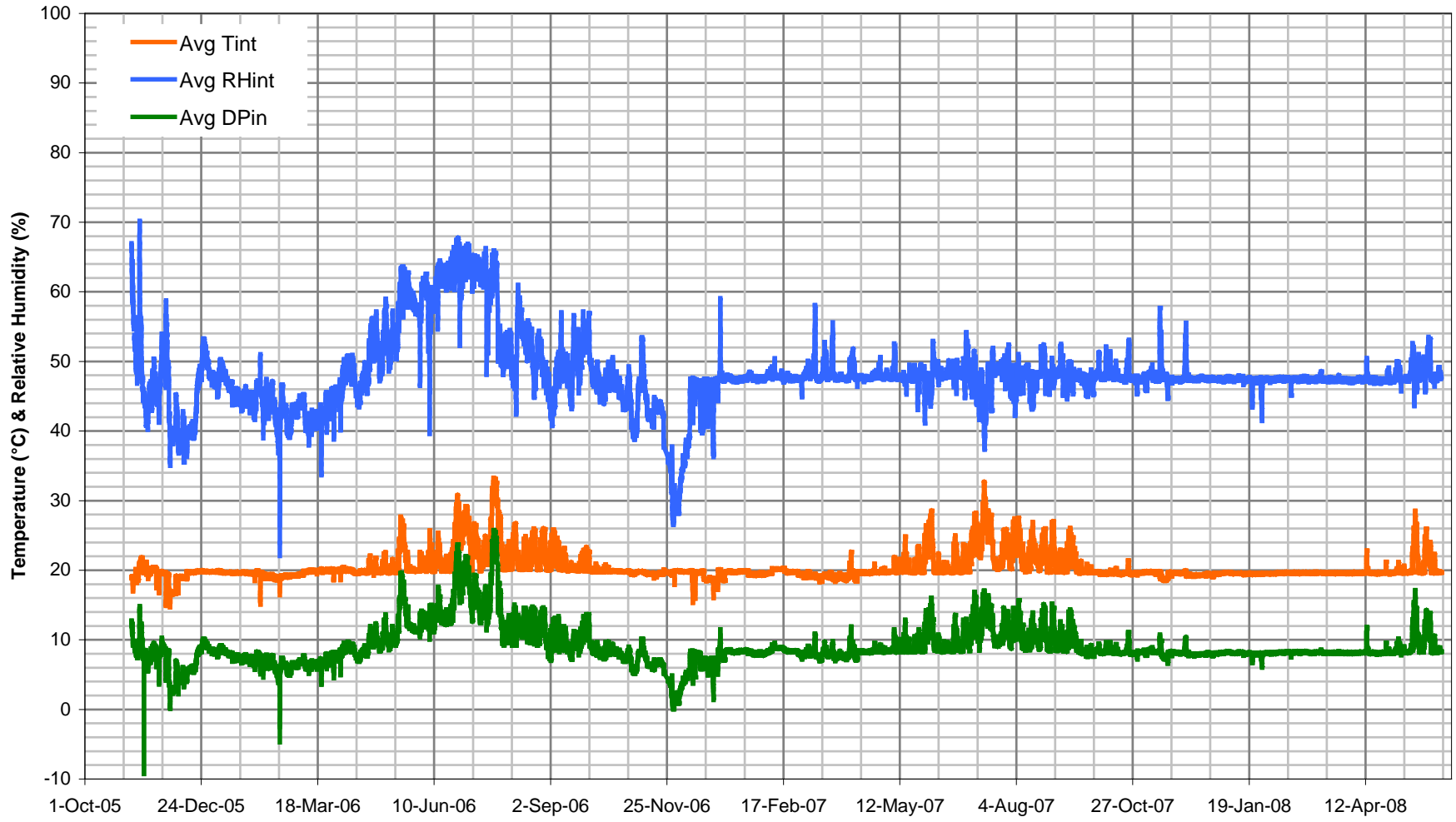



Indoor RH reality check?

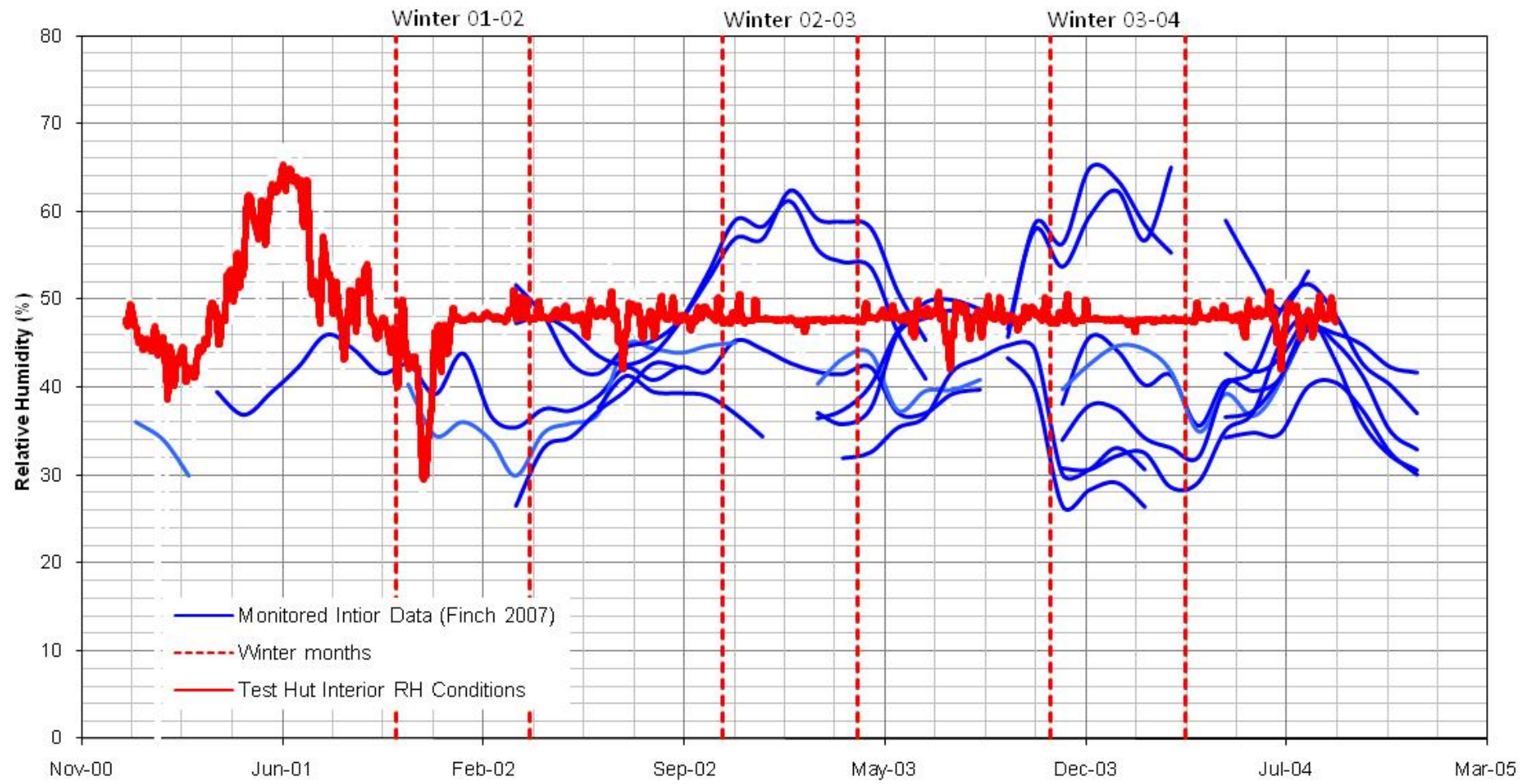

What is the Influence of the Interior Vapour Control Strategy?

1980s Energy Efficient 2x6 (airtight by sealed poly)

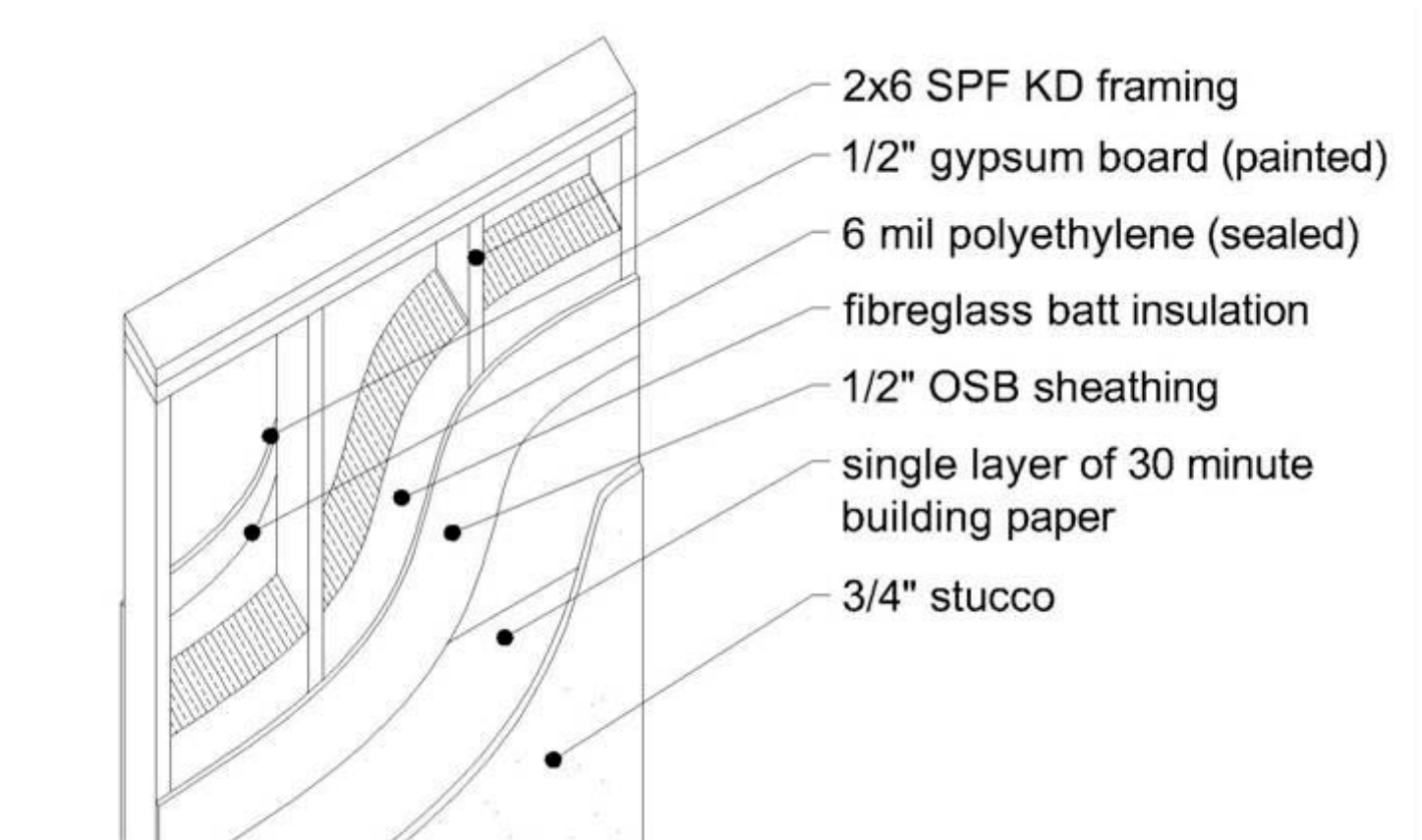

1980s Energy Efficient 2x6 (ADA, no poly)

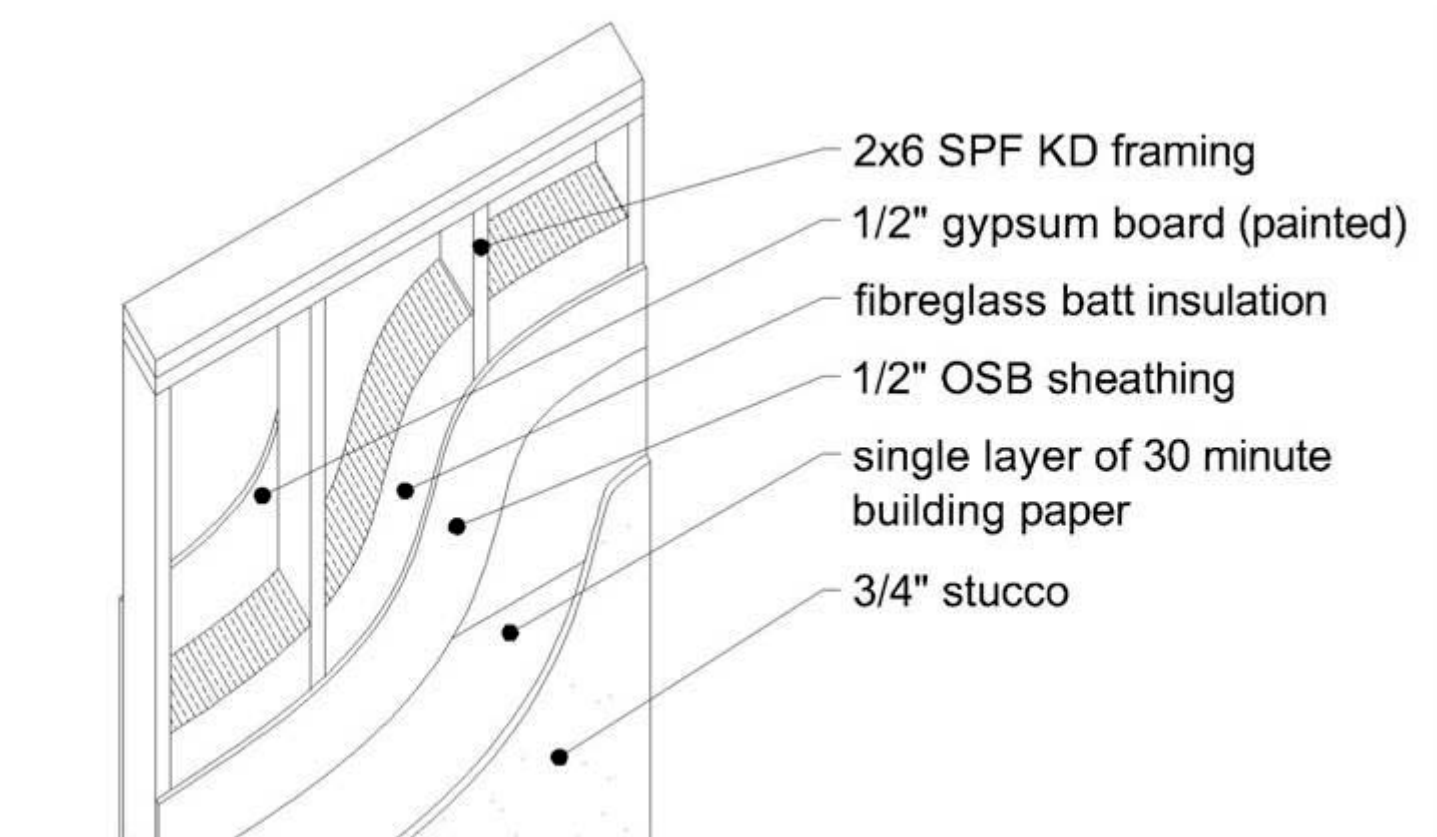

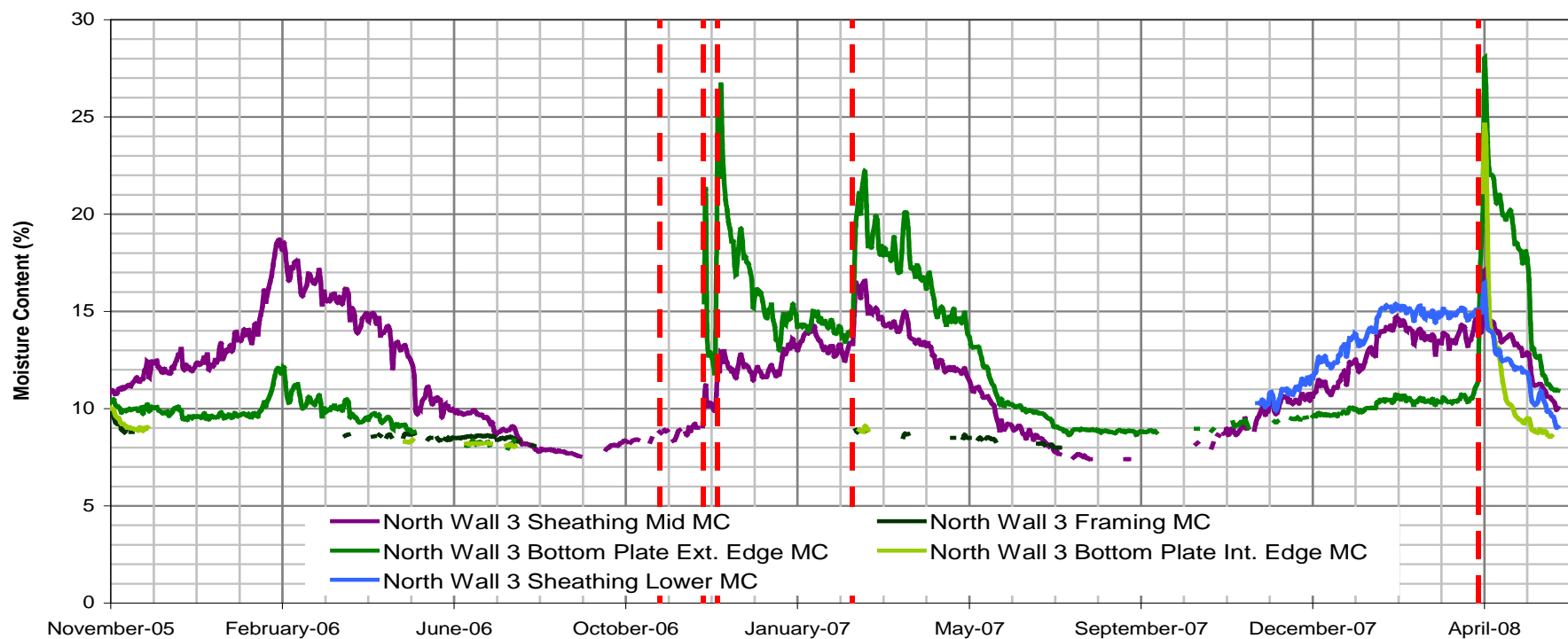
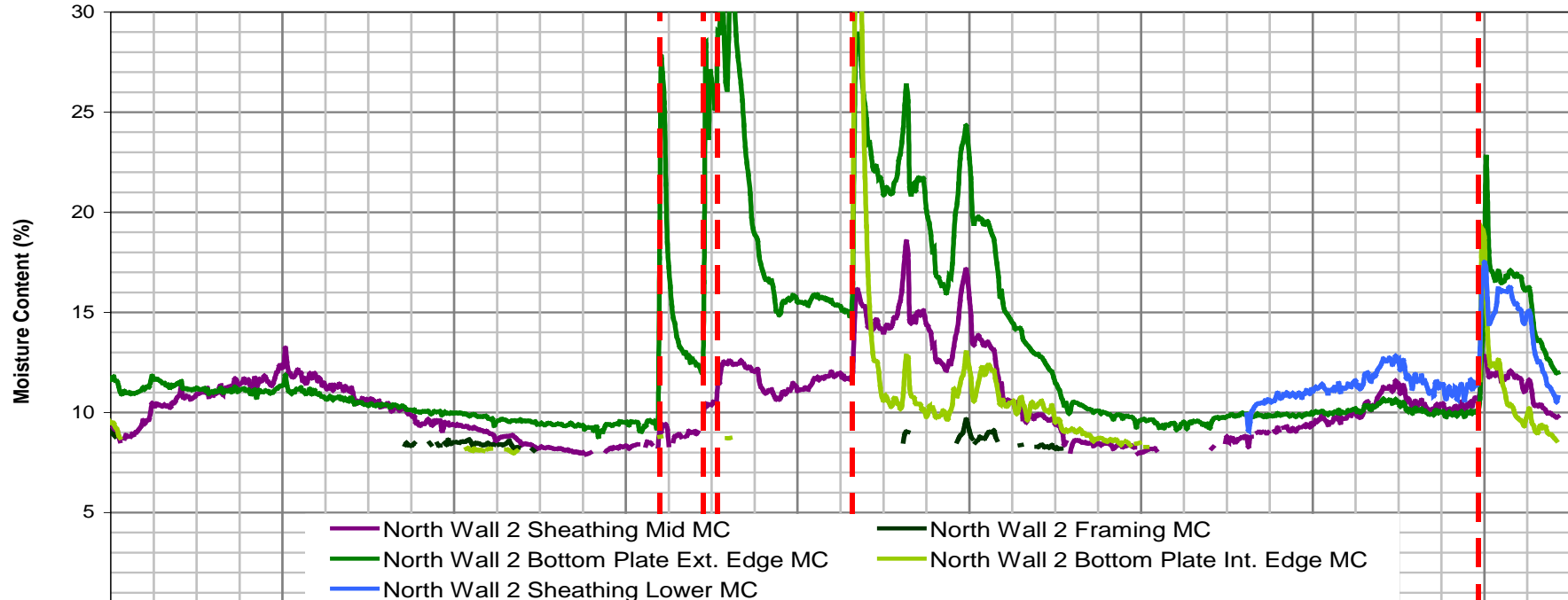

November-05 February-06 June-06 October-06 January-07 May-07 September-07 December-07 April-08

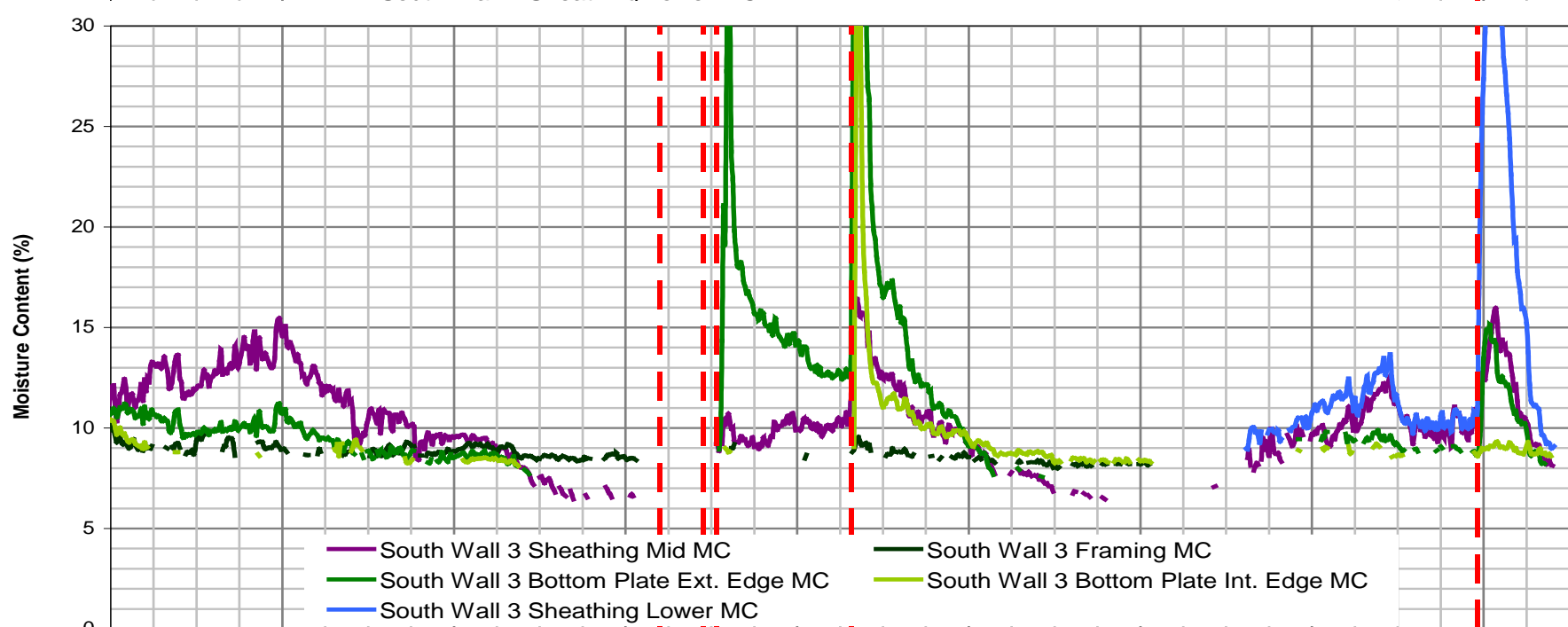
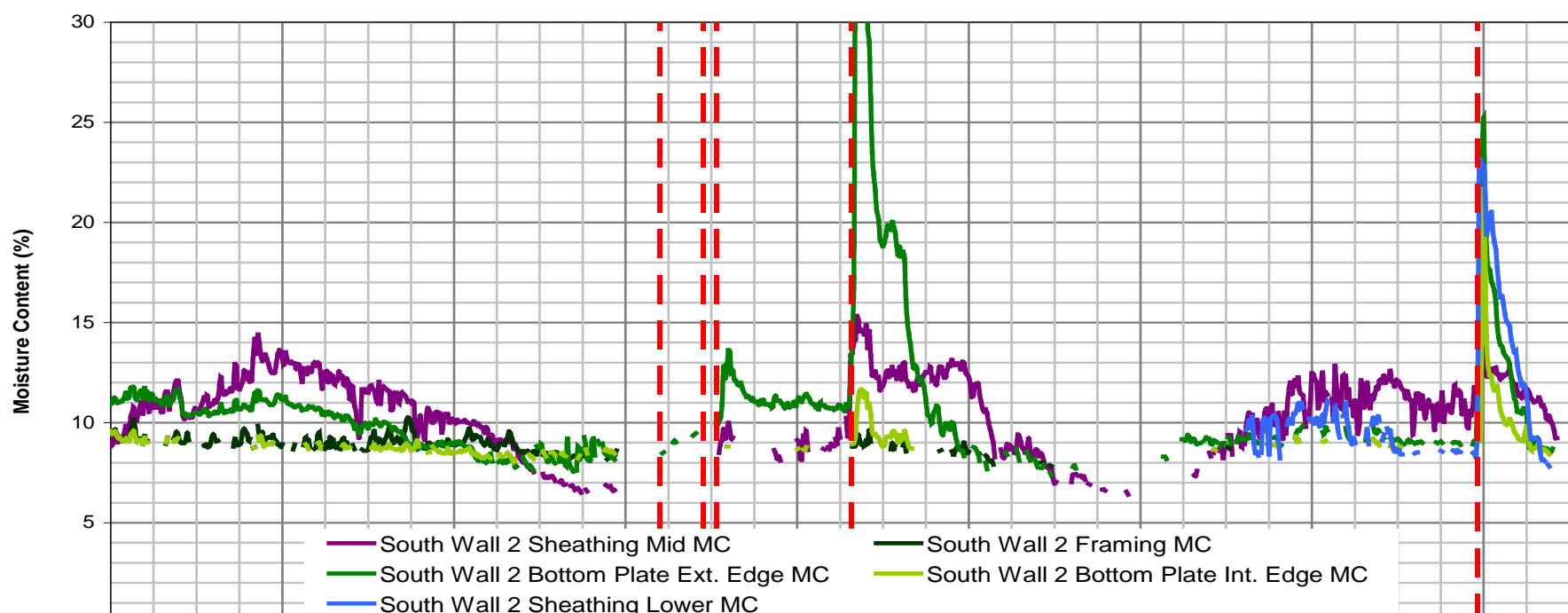

November-05 February-06 June-06 October-06 January-07 May-07 September-07 December-07 April-08

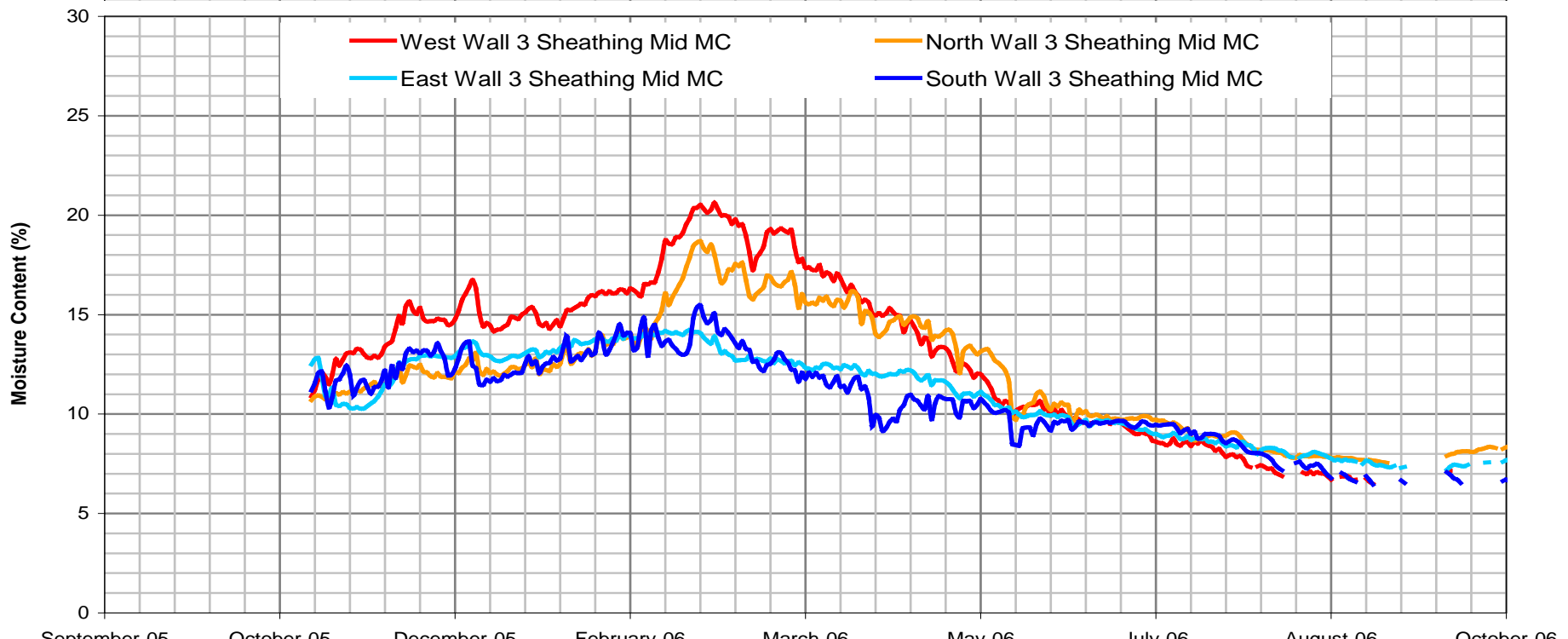
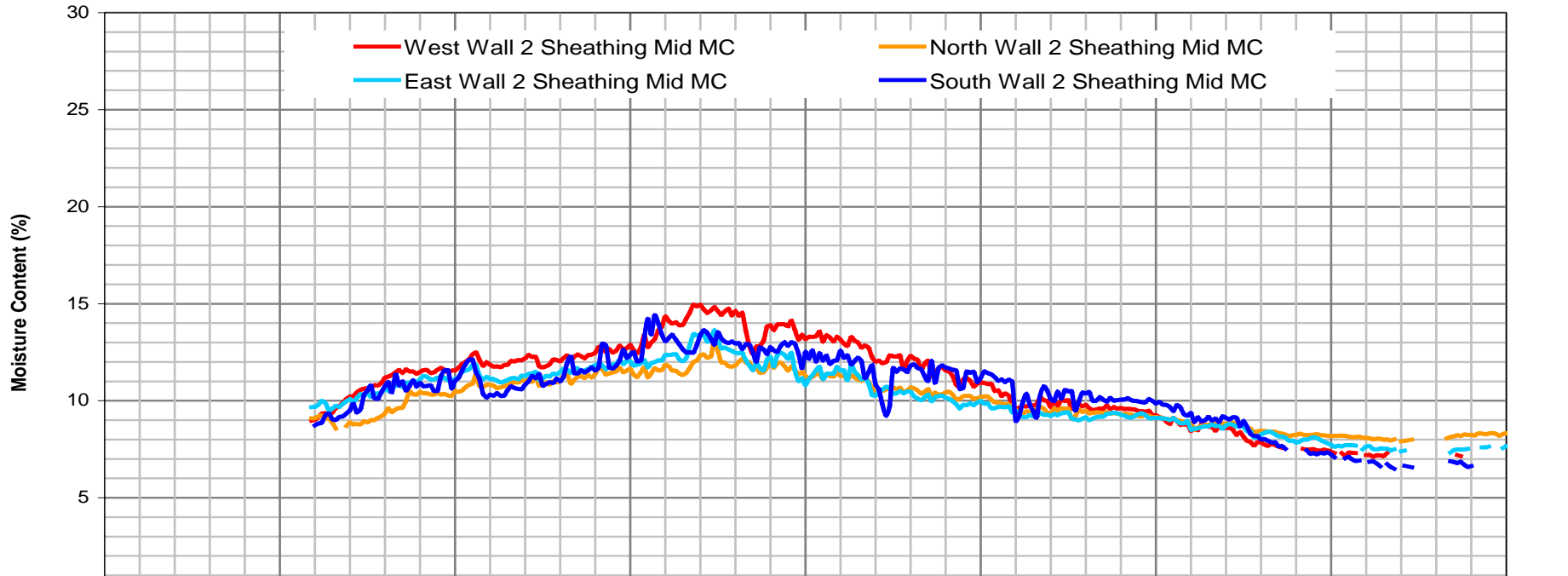

North Wall Deconstruction



Some Cracking of Stucco



Bldg paper bonded to stucco



Small amounts of mold on 1980s wall w/ poly



Less bonding on no poly wall



N3 (no poly) vs N2 (poly)



Interior of 1980s wall w/ poly



Interior of 1980s wall no poly



Influence of Interior Vapour Control Strategy

- Some interior vapour control (i.e. vapour resistance) is beneficial, especially if
 - ❑ Indoor humidity levels are high or not controlled
 - ❑ Too little drive to dry to the inside

- Too much interior vapour resistance may reduce ability to dry when
 - ❑ Significant wetting from the outside
 - ❑ Claddings w higher vapour resistance are used

What is the Influence of a Drained, Ventilated Gap?

(often referred to as a rainscreen)

Recall drying mechanisms

1. Surface Evaporation
2. Vapor movement by
 - i) Diffusion
 - ii) Convection
3. Drainage by gravity
4. Ventilation
(Intentional convection)

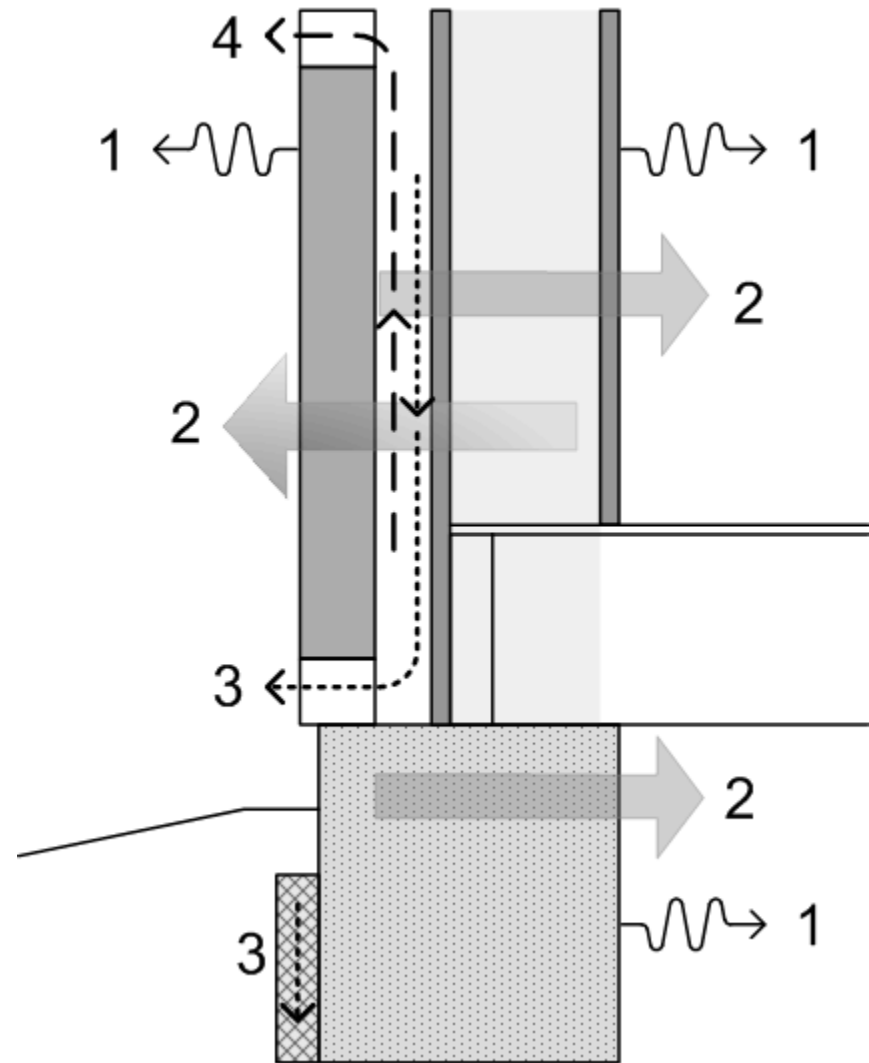

Drained, Ventilated gaps

- Permit drainage of bulk water
- Encourage drying of water on surfaces and in bounding materials

- Requirements
 - ❑ Capillary break
 - ❑ Clear drainage path down & out
 - ❑ Unrestricted airflow path between
 - ❑ Distributed (rain protected) vent openings

How big of a gap?

- Gaps <1 mm usually sufficient for drainage
- Gaps 2-6 mm significantly improve drying behind vapour resistant claddings (Smegal 2005)

- Efficacy depends not just on geometry, but also driving forces:
 - Wind pressure gradients
 - Thermal buoyancy
 - Moisture buoyancy

Flow Visualization (U of W 2004)

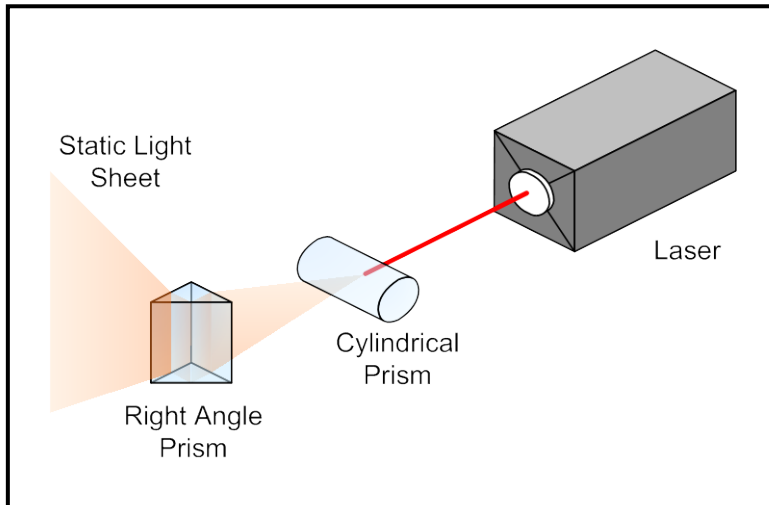

Test Details

- East-facing Brick Veneer
 - 1.2x2.4 m, Two 10x65 mm vents Top & Bottom

- Conditions
 - Wind speed 1.5-2.5 m/s
 - Wind dir NNW
 - Outdoor temp -2.5°C
 - Airspace temp ~10°C

Close-up at a mortar bridge





Results of U of W Flow Visualization

- Characterization of Flow
 - Uniform
 - Unsteady
 - Highly influenced by obstructions

- Measurement
 - Velocity on the order of 0.12 m/s
 - Flow rate of 3.6 lps/panel or 1.25 lps/m²

Gravimetric Measurement of Ventilation Effectiveness (PSU 2002)

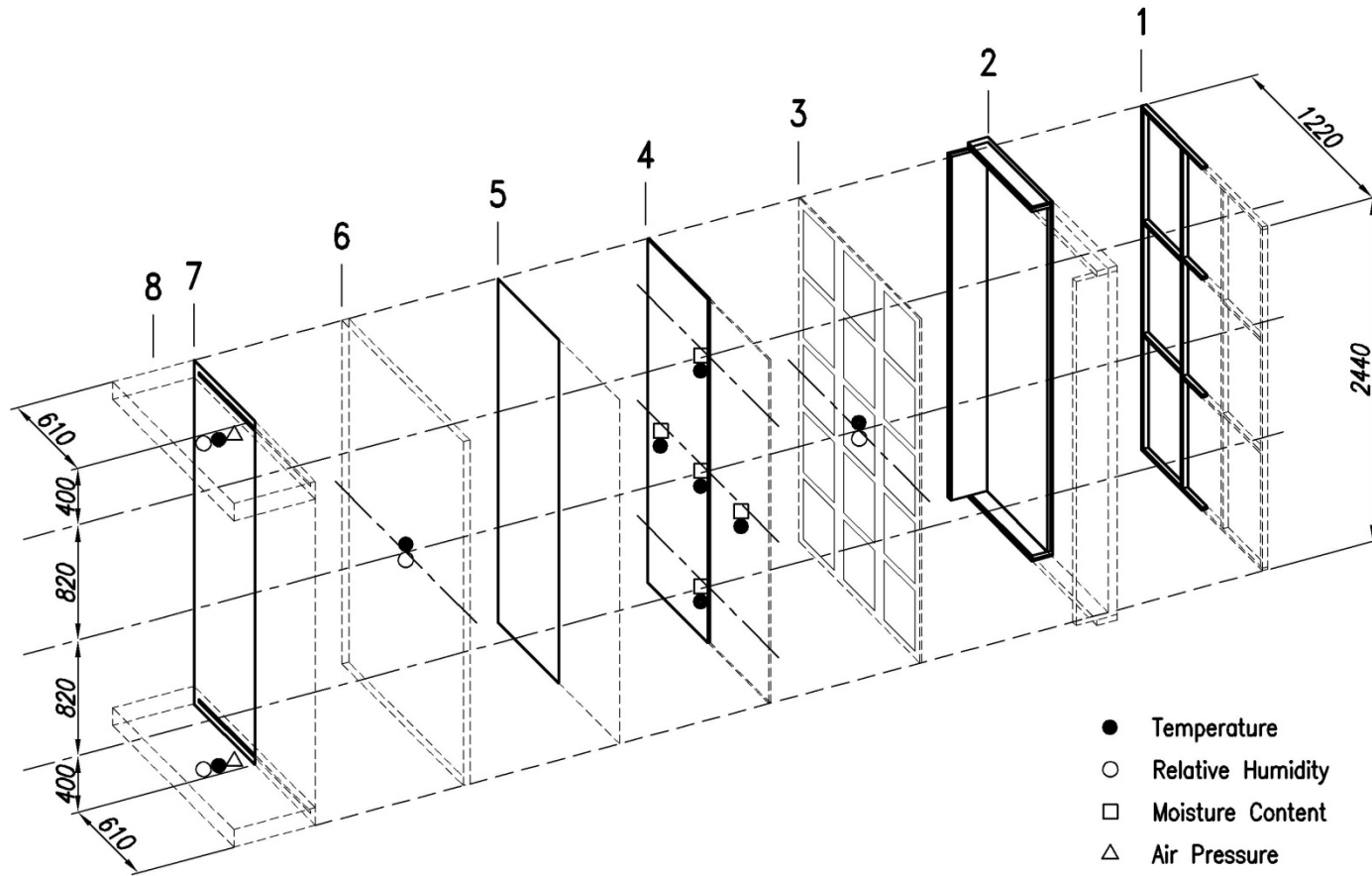
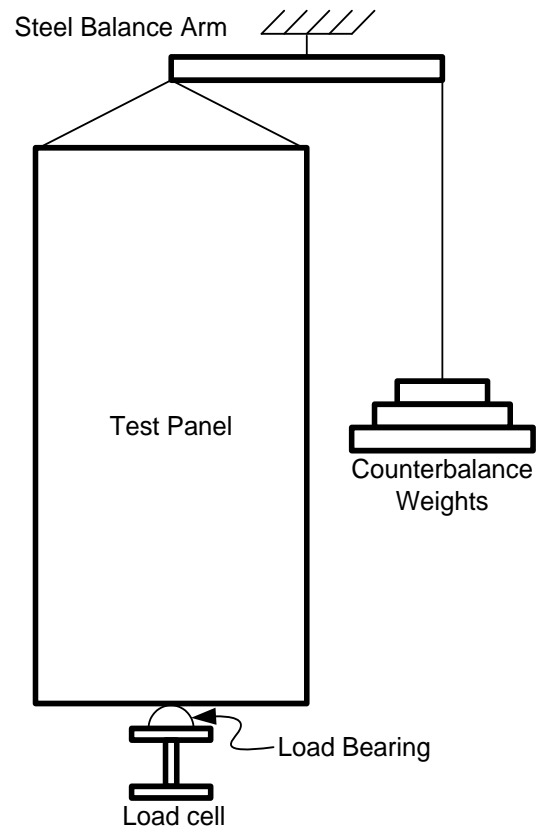
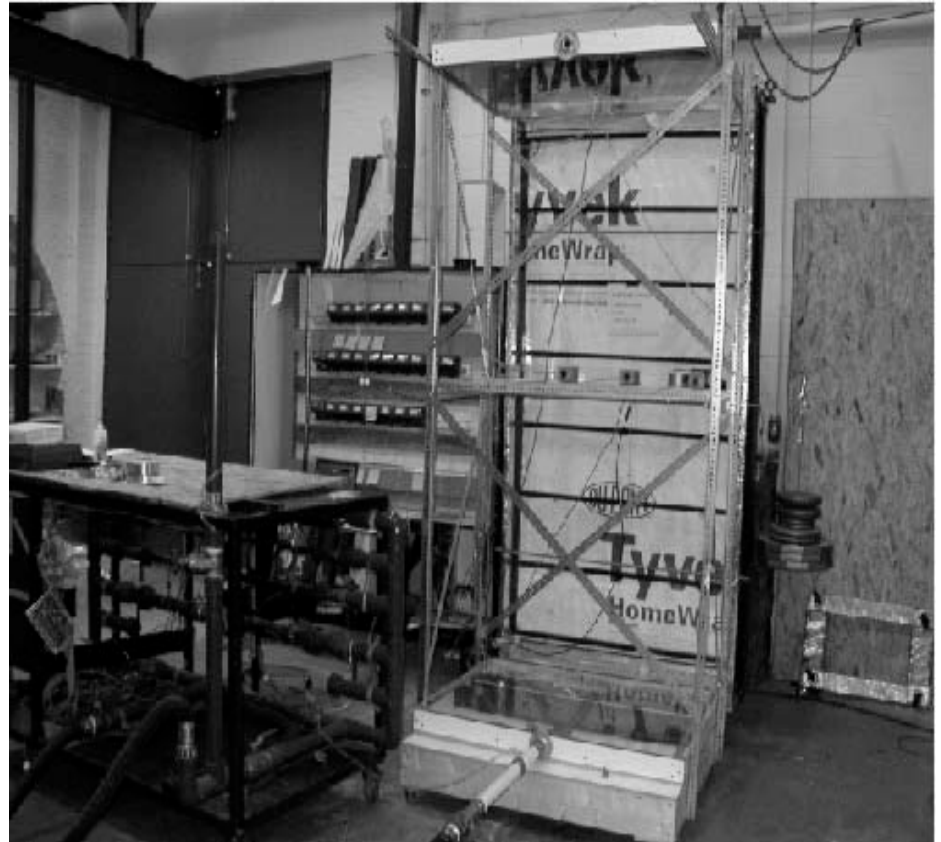

Figure 1. Exploded view of wall test panel assembly

Test Setup



Counterbalance System



Airflow manifolds connected to test panel on counterbalance system

Results of PSU Gravimetric Tests

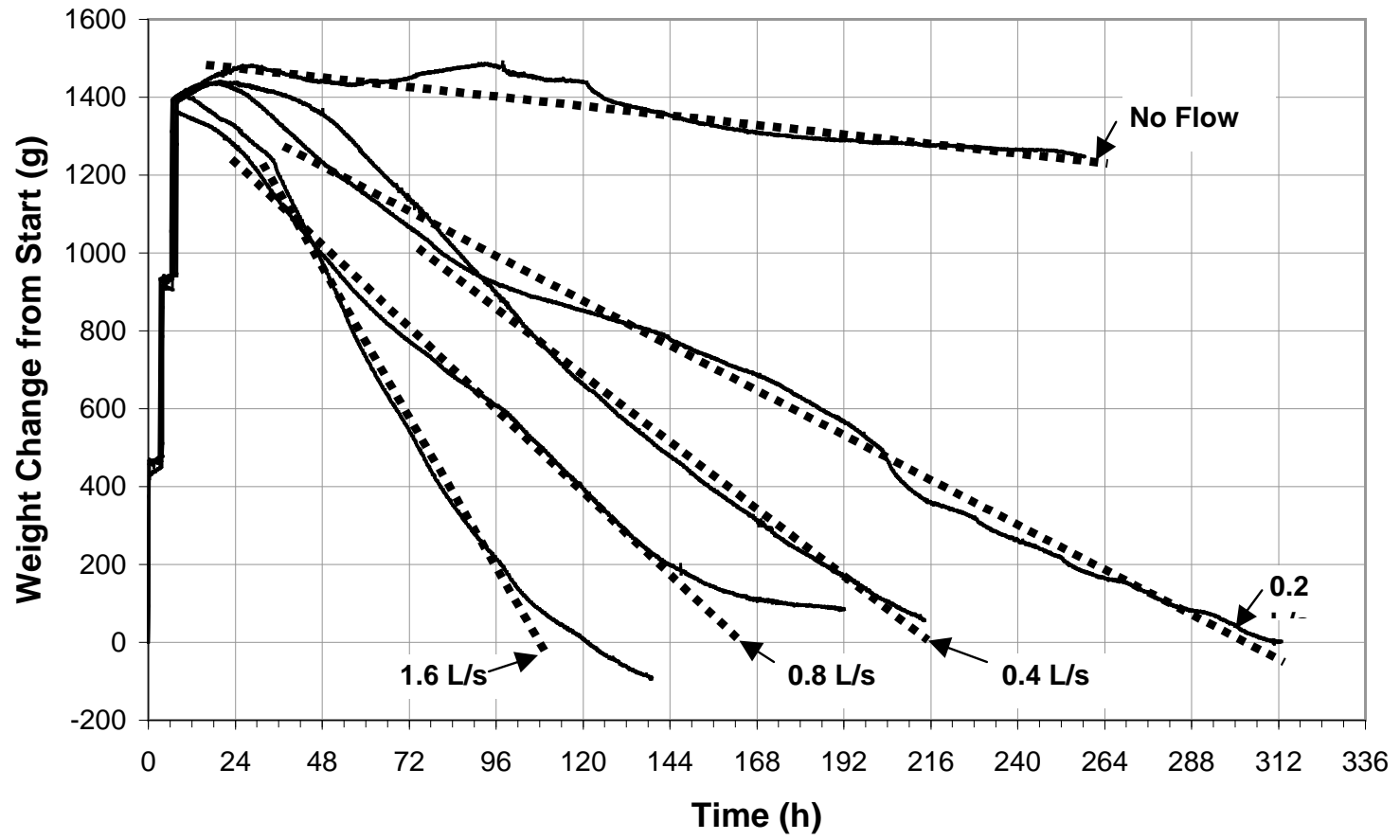

Relationship between ventilation flow rate and drying rate

But do Drained, Ventilated gaps work in the field?

1980s Energy Efficient 2x6 (airtight by sealed poly)

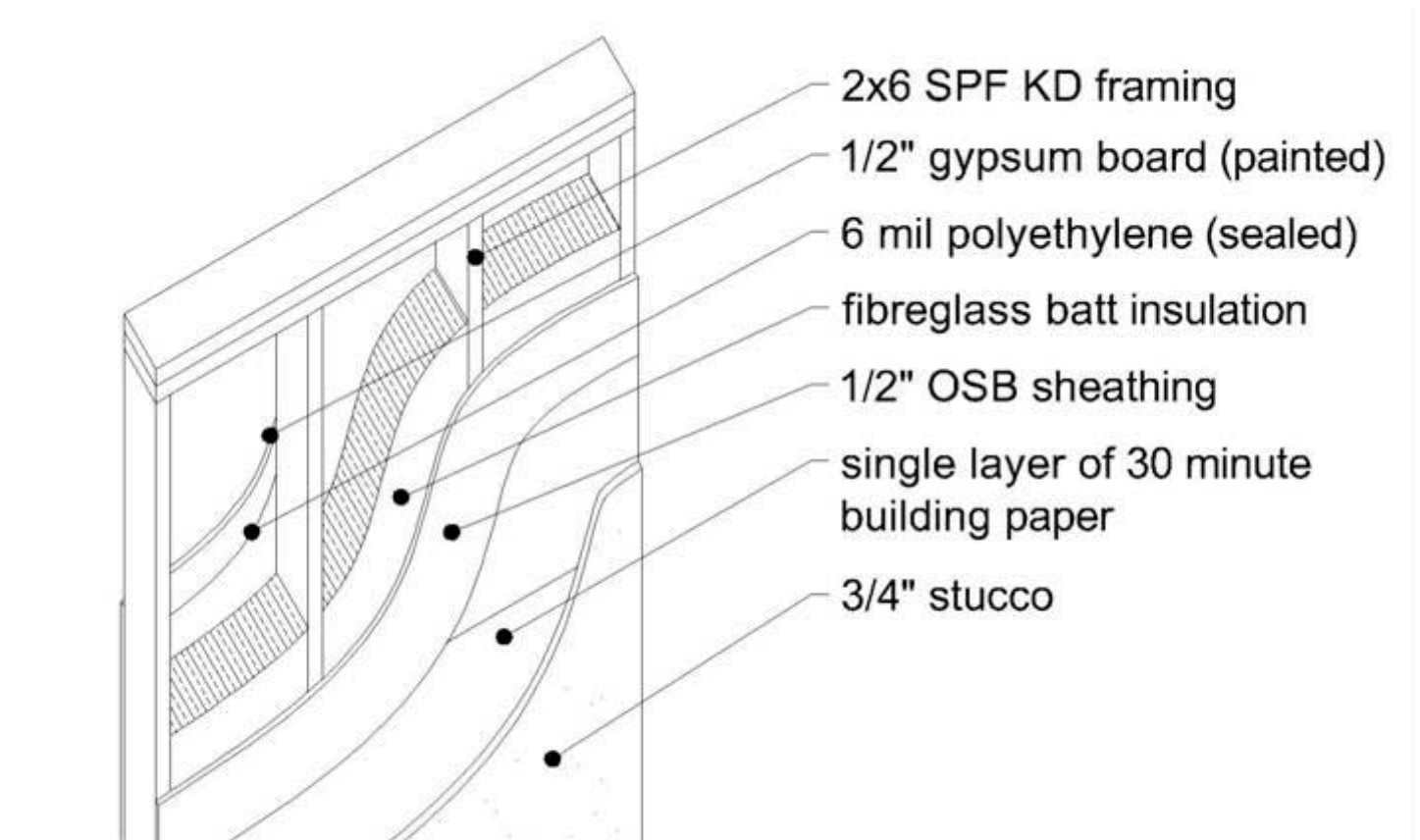

2000s Rainscreen 2x6 (poly, $\frac{3}{4}$ " drained, ventilated gap)

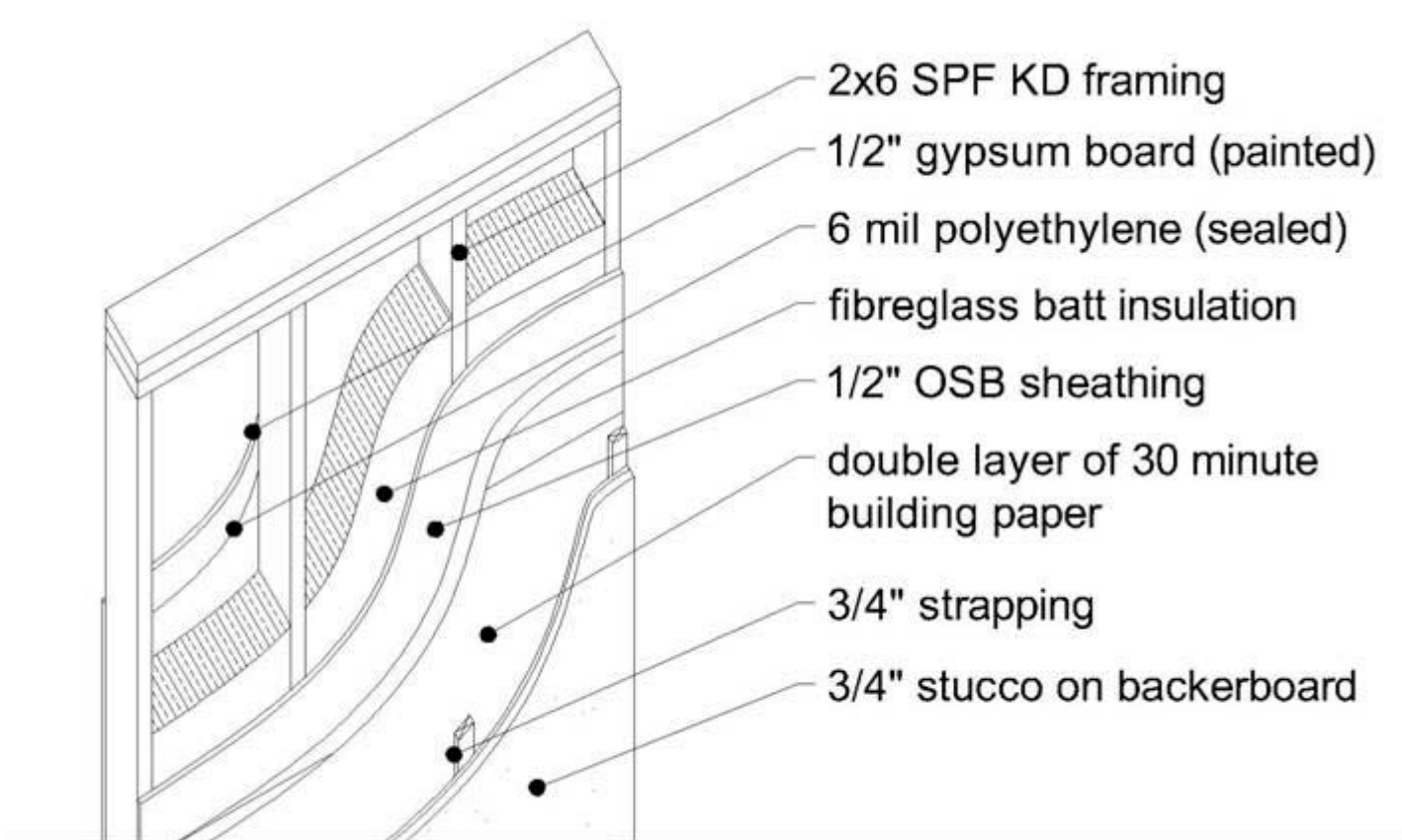

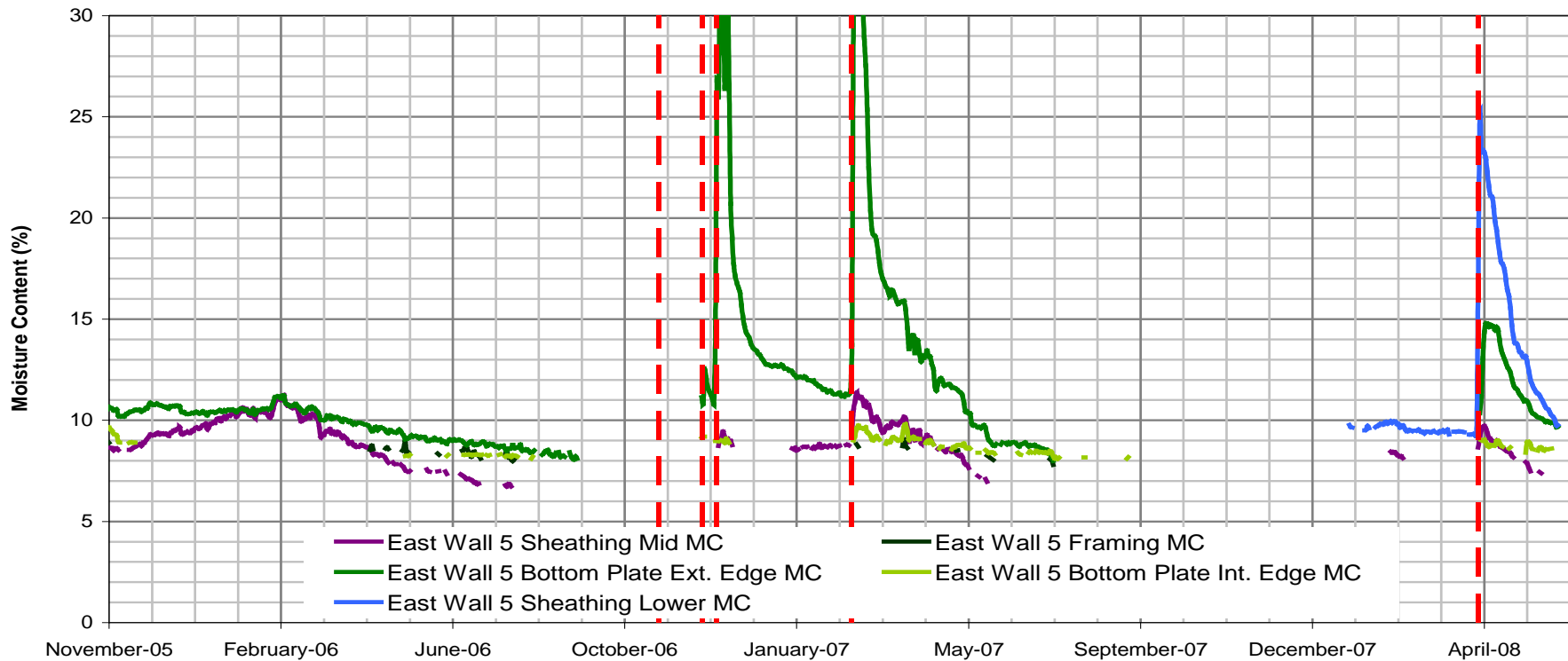
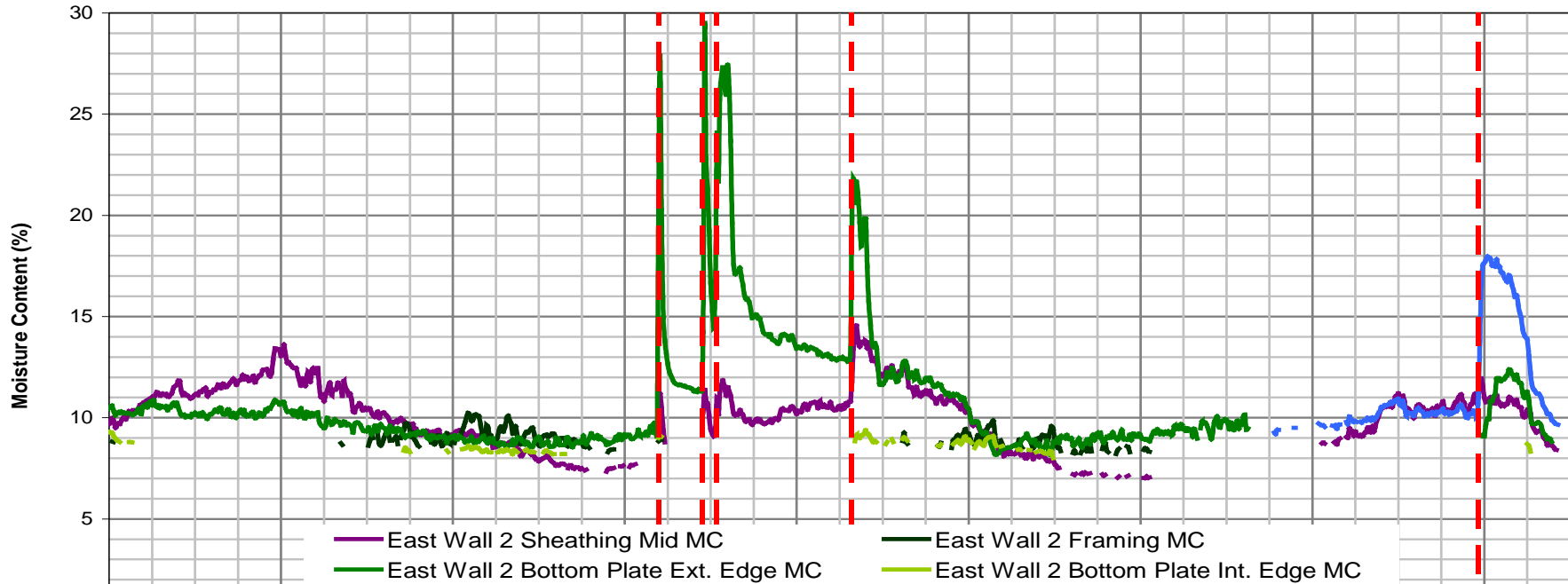

November-05

February-06

June-06

October-06

January-07

May-07

September-07

December-07

April-08

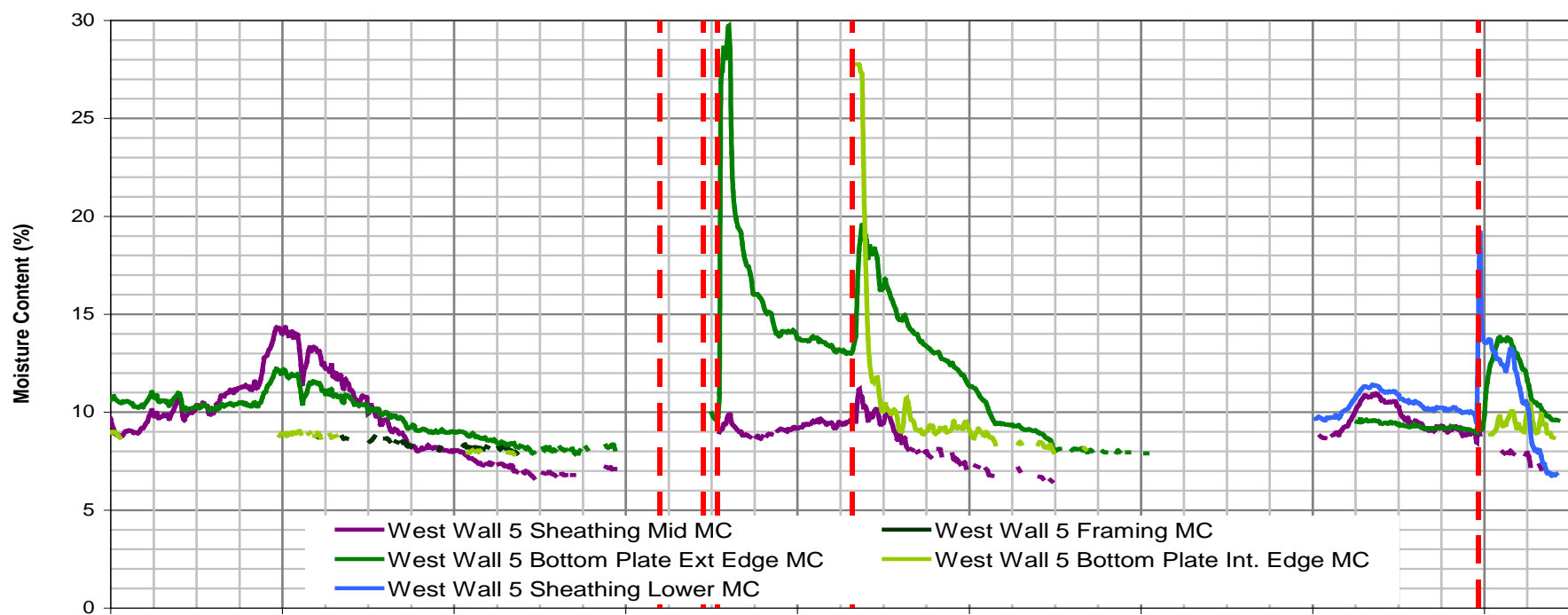
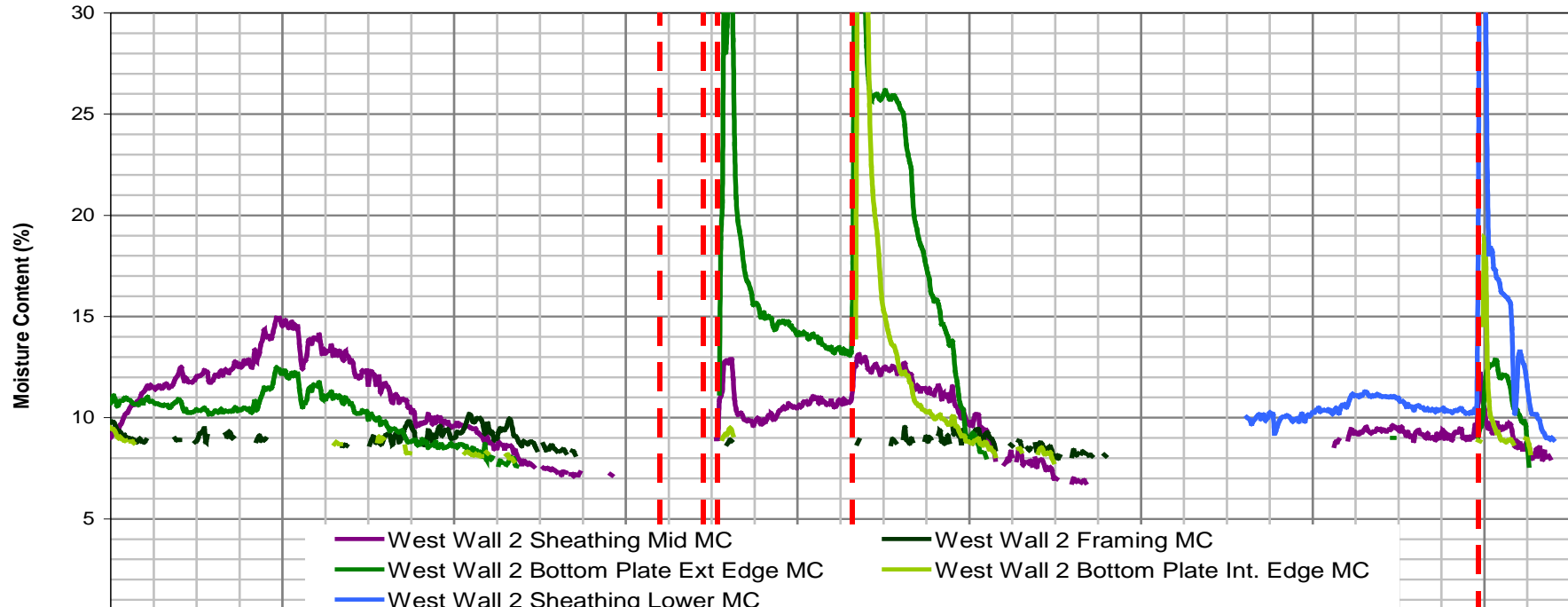

November-05 February-06 June-06 October-06 January-07 May-07 September-07 December-07 April-08

RH behind stucco cladding 1980s vs 2000s w/poly (west)

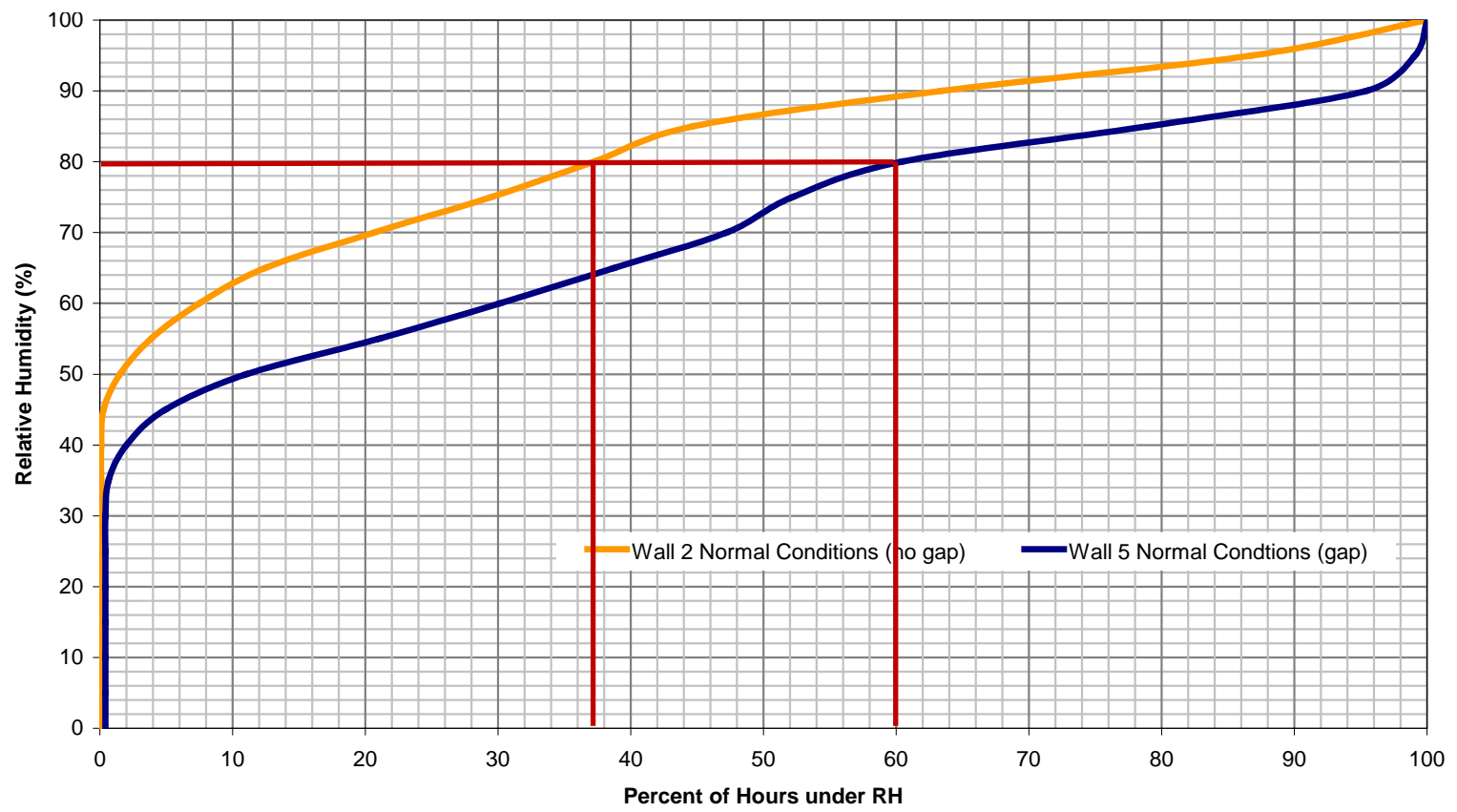

RH behind stucco cladding 1980s vs 2000s no poly (west)

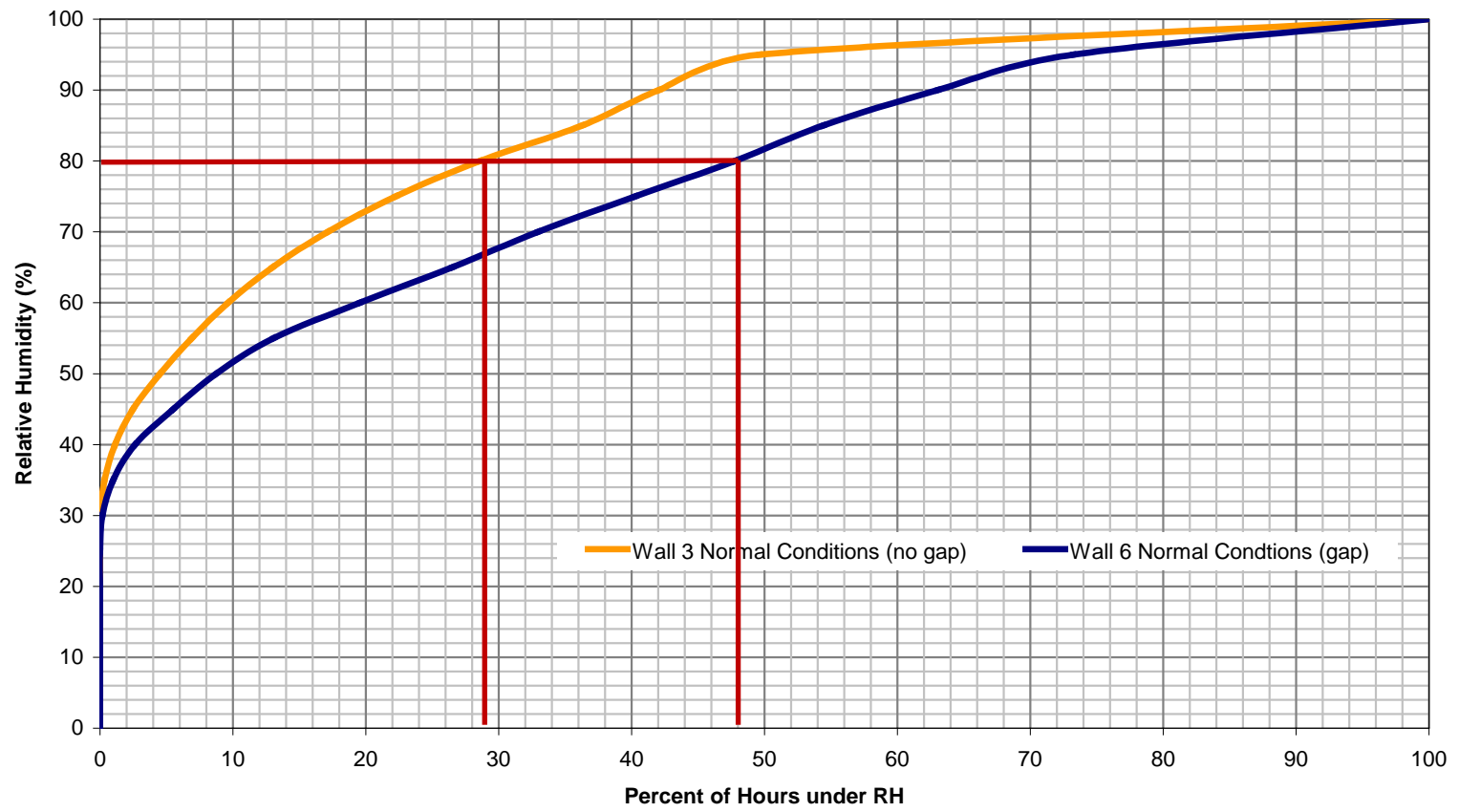

RH behind stucco cladding 1980s vs 2000s no poly (east)

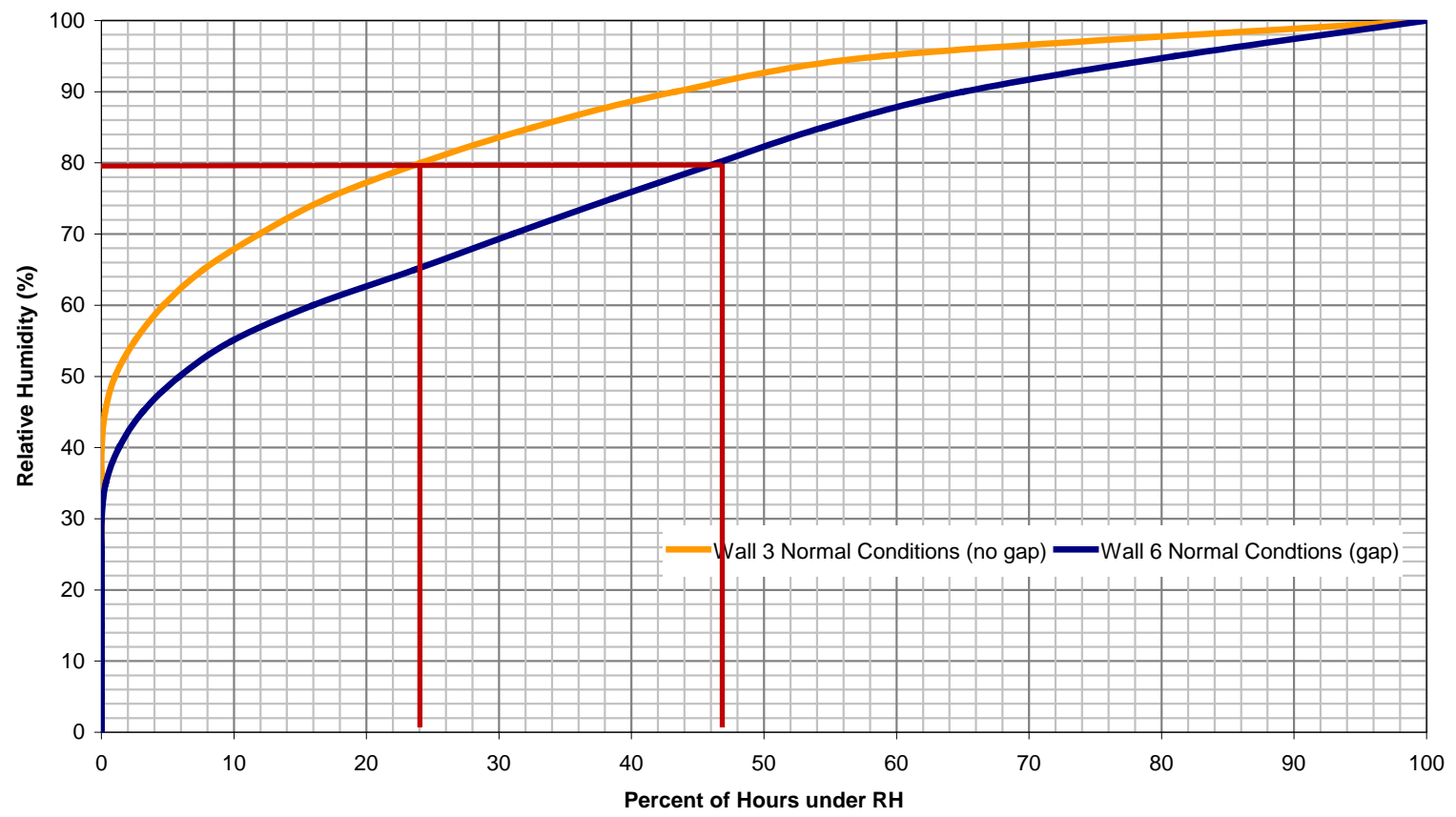

2000s wall, ventilated w poly



Little sign of moisture

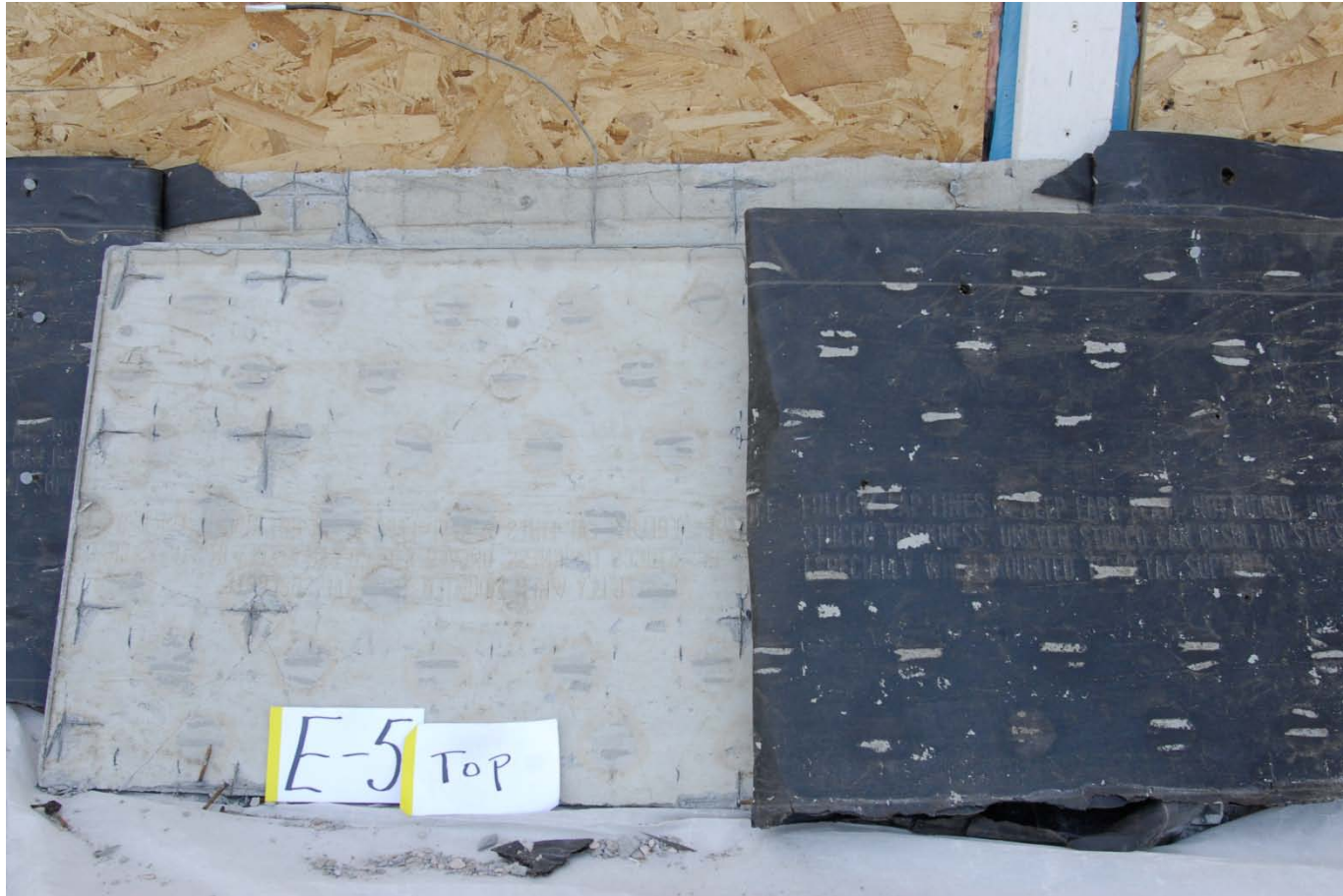







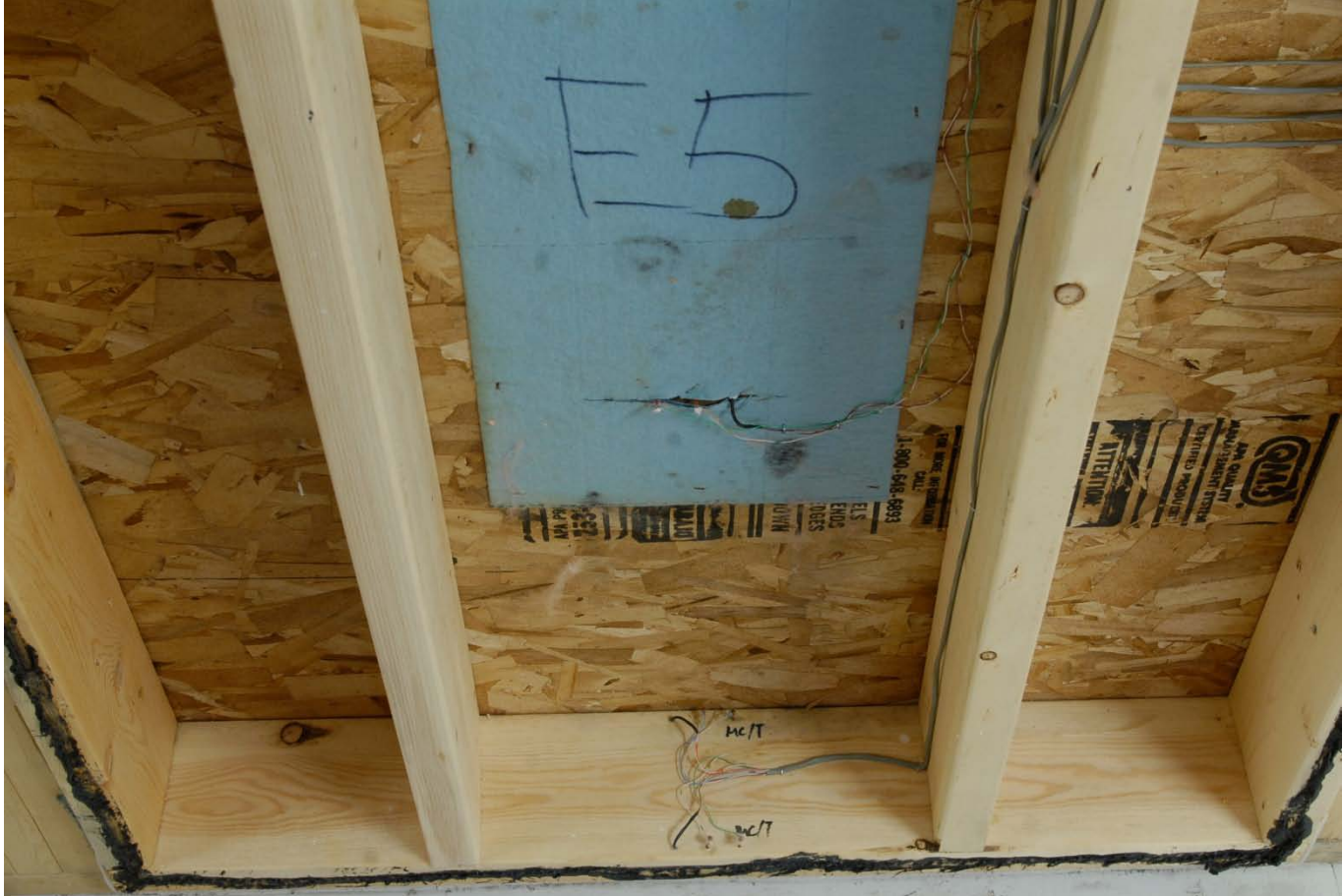

Influence of a Drained, Ventilated Gap

- Drained Ventilated Gaps were shown to
 - Reduce hours of high RH behind the cladding
 - Reduce the OSB drying time
 - Potential to reduce average MC of the OSB
- Ventilation may not be sufficient for high exterior moisture loadings & cases where there is little drive (e.g. north-facing walls)

What is the Influence of Exterior Insulation?

Next Gen (2005+) 2x6 Wall (no poly, drained, exterior insulated)

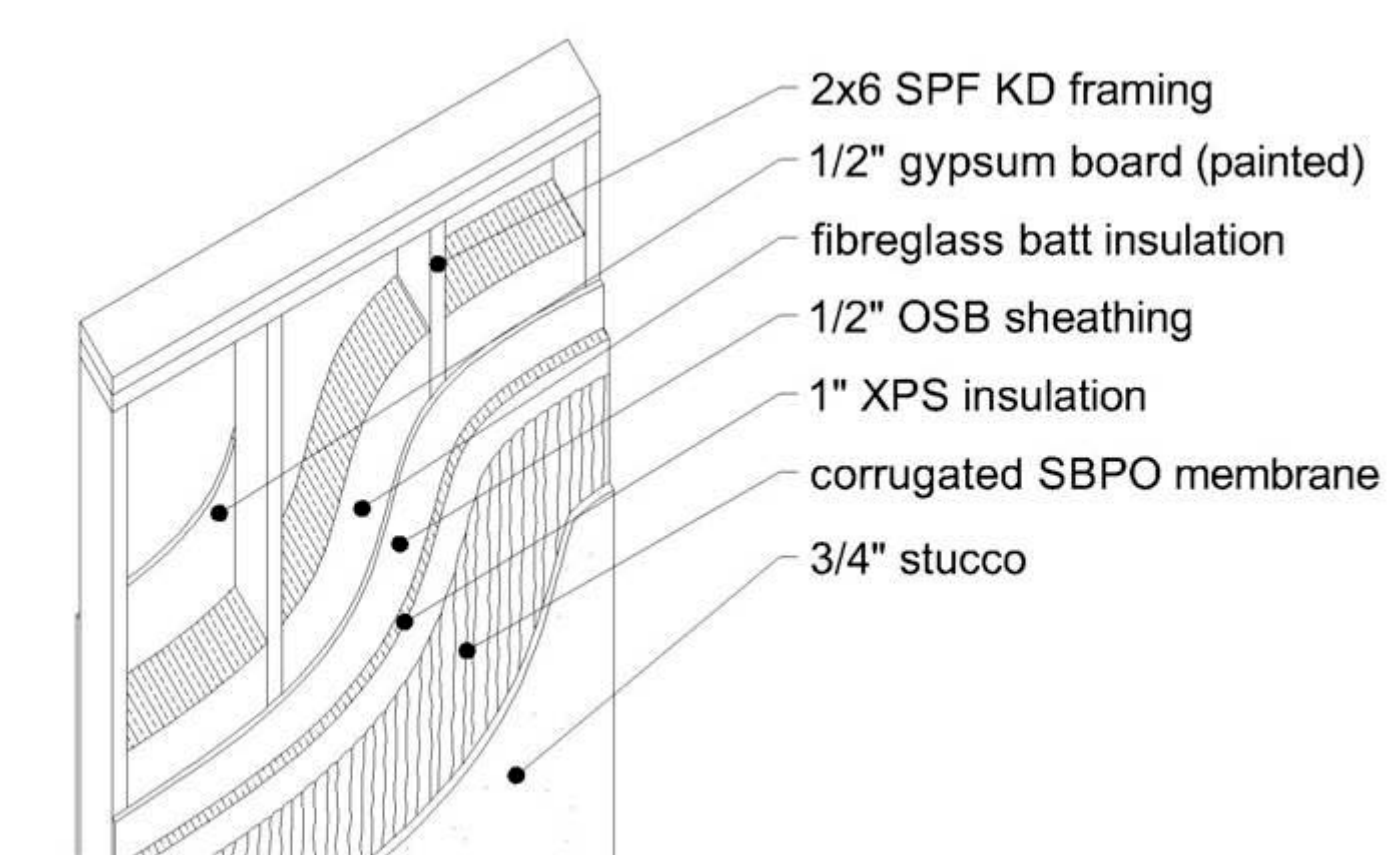

Exterior Insulation

- Increases the wintertime temperatures of the interior wood components to
 - Increase the average RH & decrease the equilibrium moisture content
 - Reduce the potential for air leakage condensation

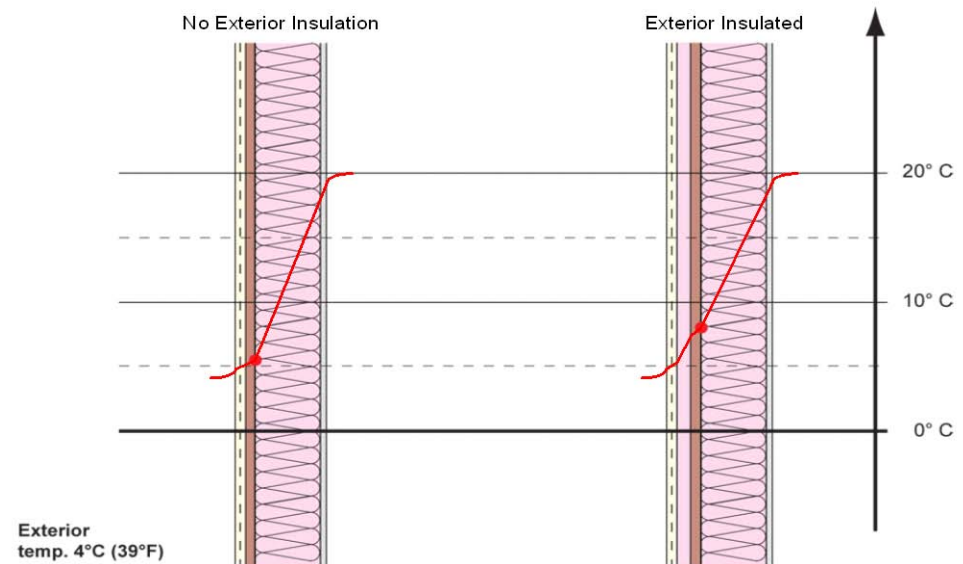

Foam Exterior Insulation

- Throttles vapor diffusion
 - Disconnects sensitive interior materials from wet, absorptive claddings but..
 - Also limits the amount of drying that can occur from the OSB to the outside

Permeance of XPS

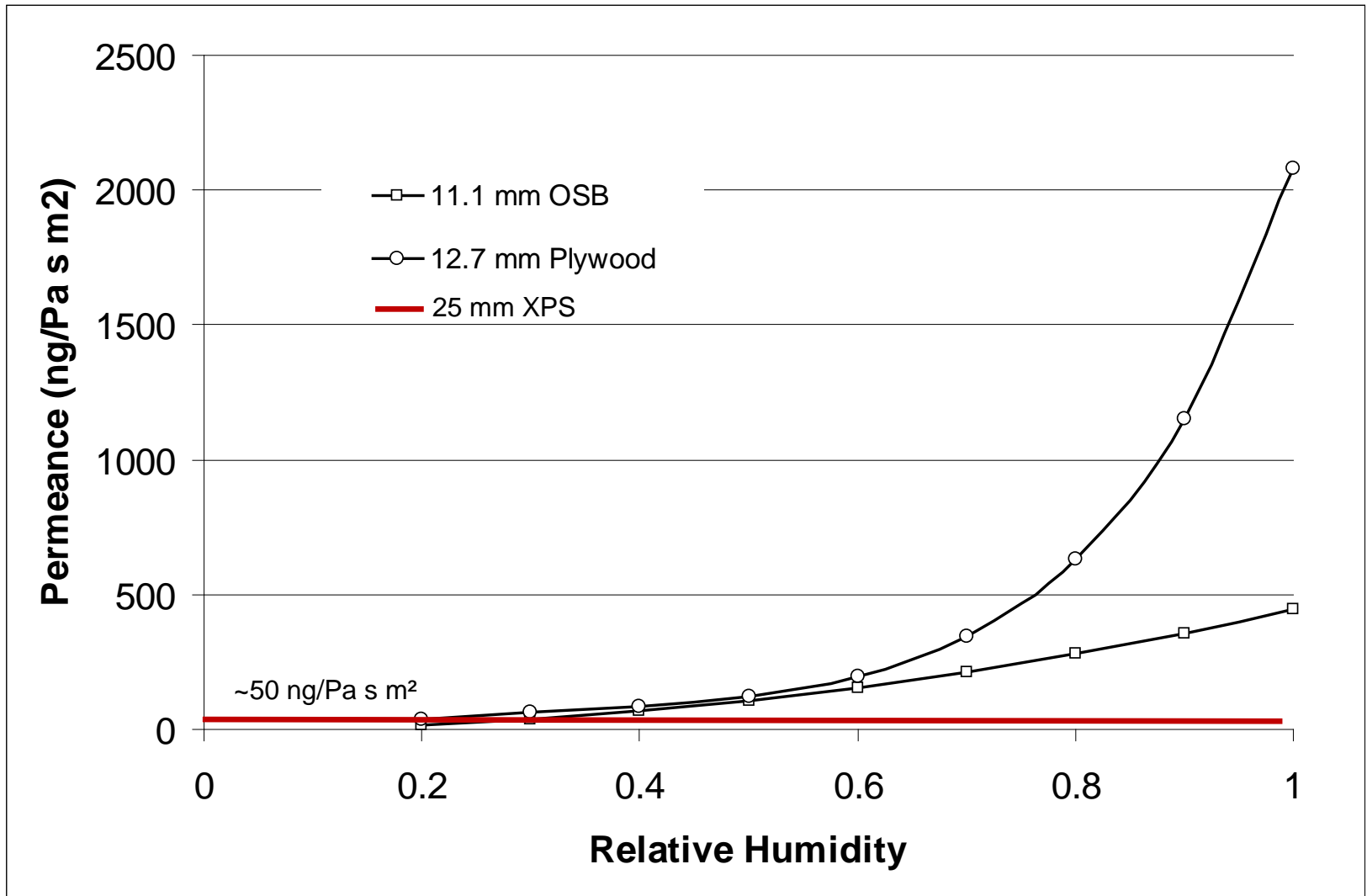

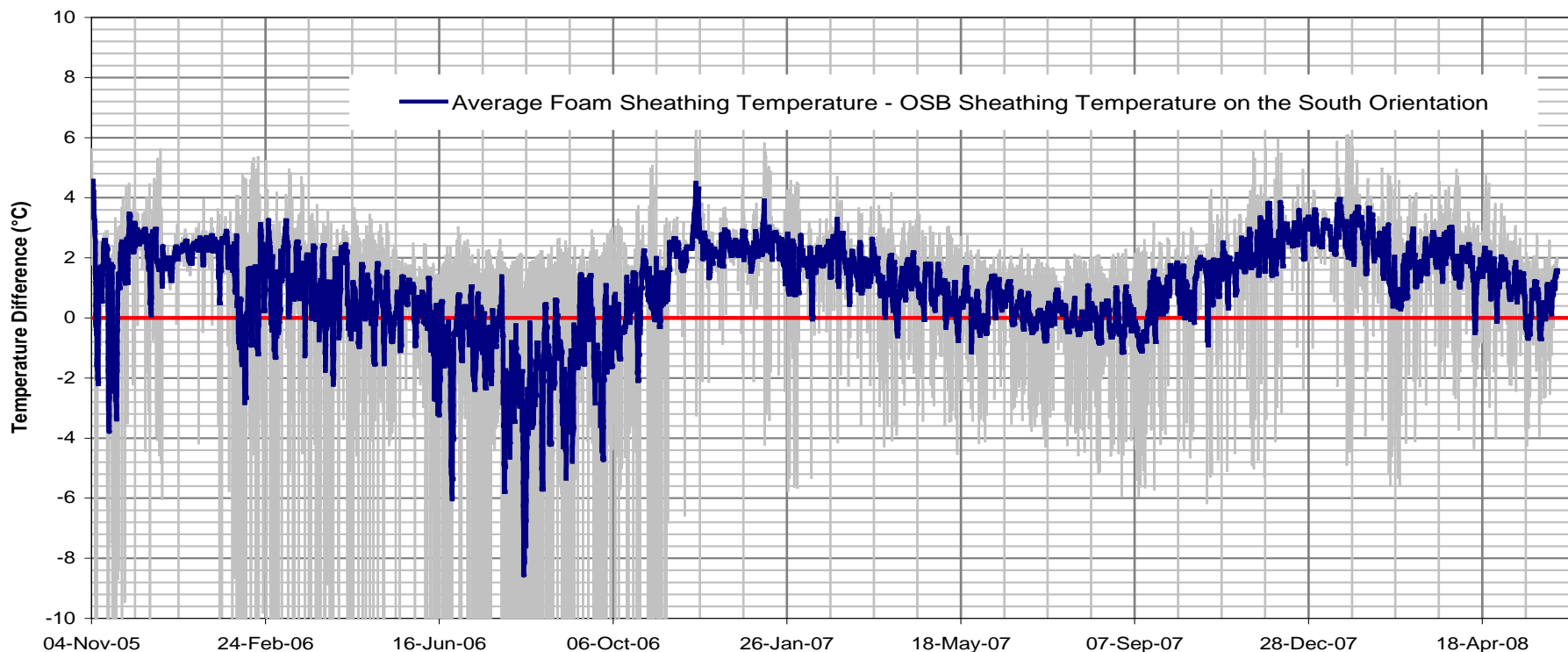
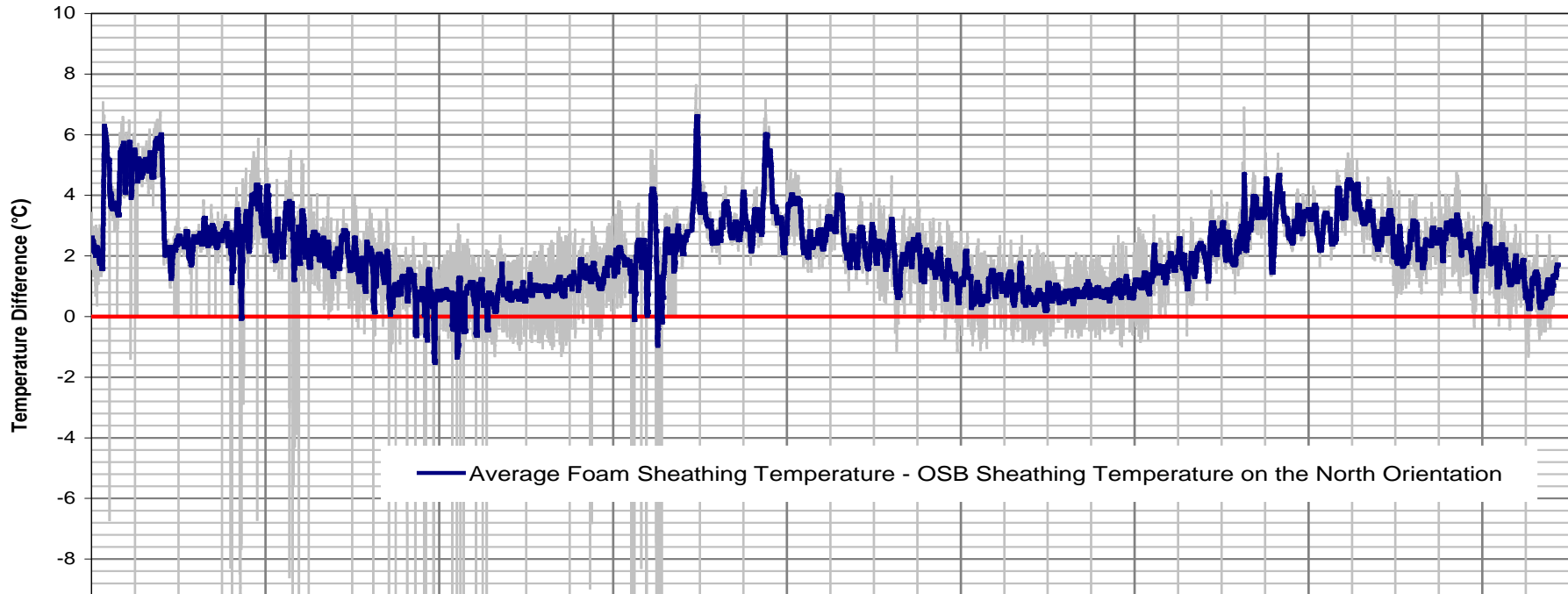

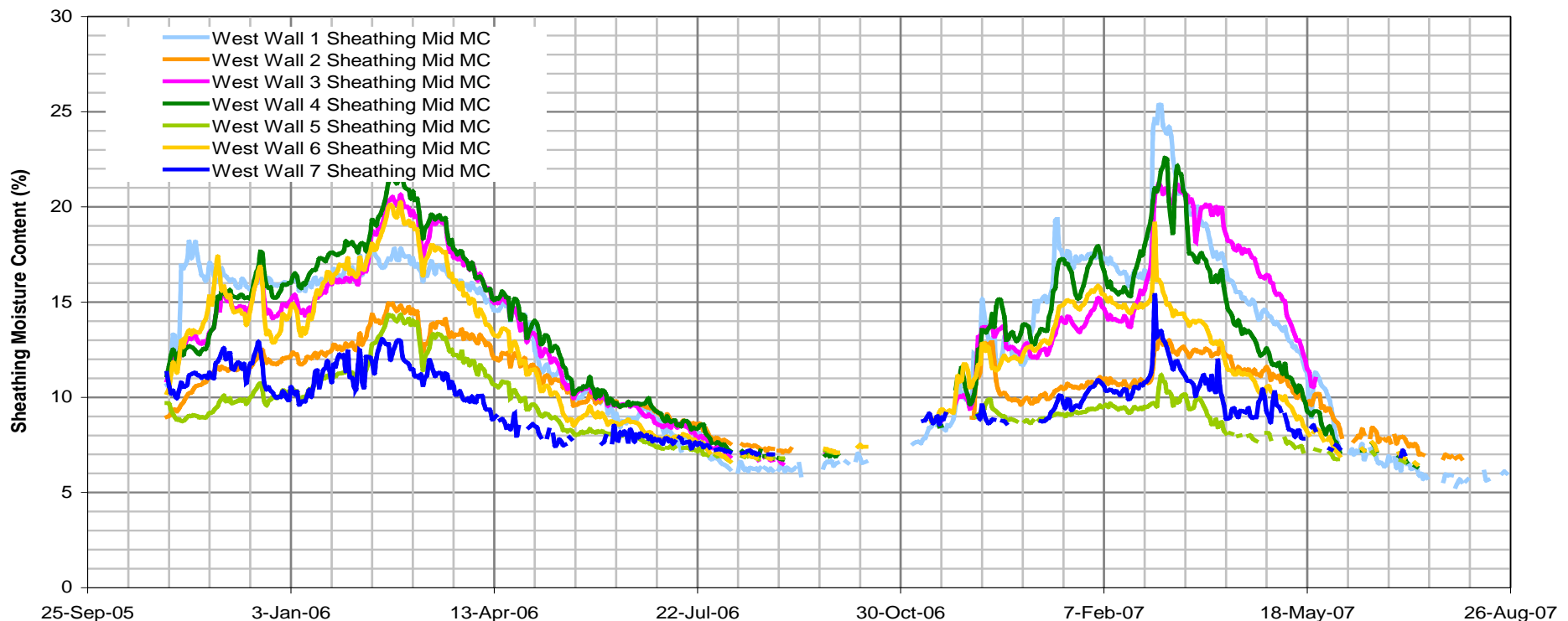
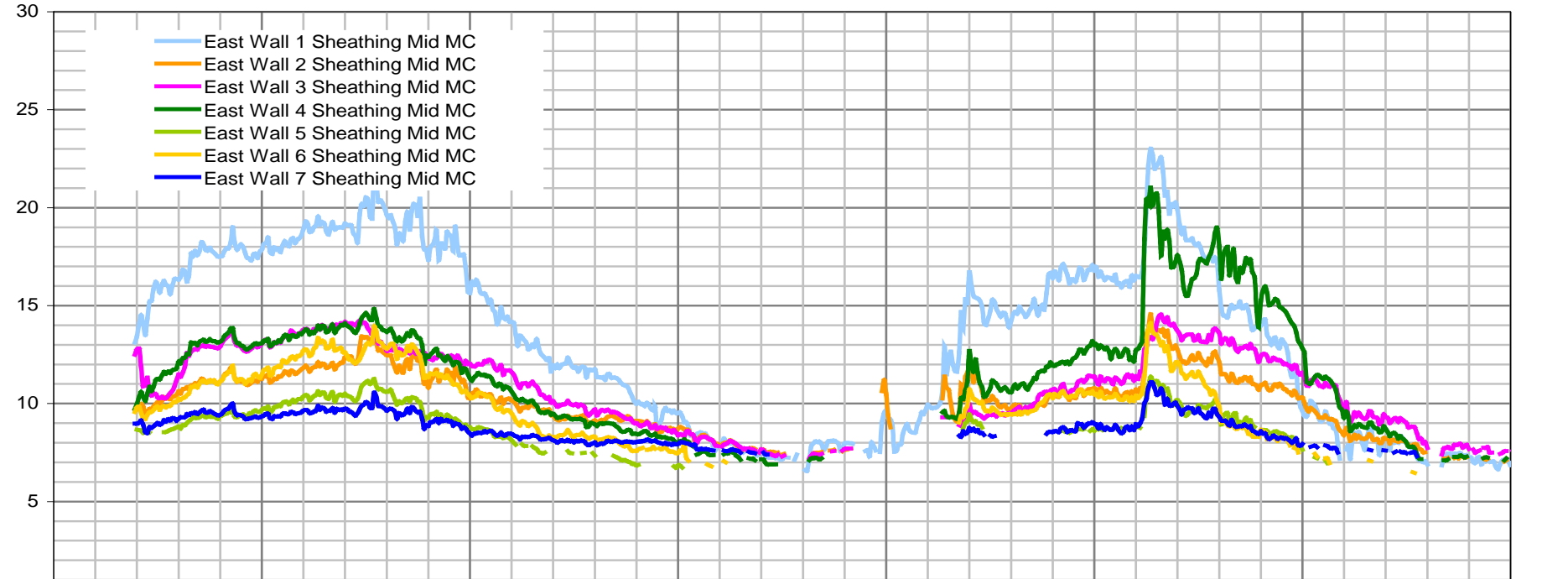

2005+ Wall, drained, ext insulated, no poly







Drainwrap looks new

www.BuildingScience.com



OSB is pristine



Only moderate staining from leaks



Influence of Exterior Insulation

- Exterior Insulation offers a number of benefits for future walls:
 - Improved energy performance
 - Reduction of air leakage condensation potential
 - Reduced EMC for wood components
 - Reduced sensitivity to cladding moisture levels
- Questions about the ability to dry water trapped between low perm foam insulations and moisture sensitive wood sheathings

Future work: Phase 3

- Reconstruct walls with new materials & sensors
- Install wetting system on exterior of OSB sheathing (under WRB)
- “better” (i.e. code compliant) stucco?
- Different interior conditions?

Thank you